



BIDDING DOCUMENT

FOR

THE PROCUREMENT

OF

**PACKAGE-IV : Fabricated materials (Iron works) for
Chinggad RM, Surkhet**

IFB (invitation for bid) No.: IWRM/04/2023

Issued by

**Integrated Water Resources Management Programme
Helvetas Nepal**

Birendranagar, Surkhet

Date of issue: 03 January 2023



Abbreviations

BDS.....	Bid Data Sheet
BD	Bidding Document
EQC	Evaluation and Qualification Criteria
GCC	General Conditions of Contract
IFB	Invitation for Bids
ITB	Instructions to Bidders
SBD.....	Standard Bidding Document
SCC	Special Conditions of Contract
SoR	Schedule of Requirements
TS	Technical Specifications
VAT	Value Added Tax

STANDARD BID DOCUMENT

Table of Contents

	Page No.
1. INVITATION FOR BID (IFB)	2
2. INSTRUCTIONS TO BIDDERS (ITB)	4
3. BID DATA SHEET (BDS)	8
4. EVALUATION AND QUALIFICATION CRITERIA (EQC)	9
5. BID FORM AND PRICE SCHEDULE	10
6. SCHEDULE OF REQUIREMENTS (SOR)	14
7. SPECIFICATIONS & QUALITY ASSURANCE	15
8. GENERAL CONDITIONS OF CONTRACT (GCC)	27
9. SPECIAL CONDITIONS OF CONTRACT (SCC)	33
10. SAMPLE FORMS AND FORMATS	34
11. ANNEX-I	38
12. ANNEX-II: SCHEME WISE MATERIAL SUMMARY	42



Handwritten signature

1. INVITATION FOR BID (IFB)

INVITATION FOR BIDS

Date of first publication: 03 January 2023

1. Integrated Water Resources Management Programme, Helvetas Nepal, Birendranagar, Surkhet invites **Sealed Bid** from the interested and competent suppliers/vendors for the supply and delivery of various construction materials for drinking water supply and sanitation scheme as per following packages:

Dailekh District

- Package-I Various construction materials (HDPE Pipe, rebar, plain wire, barbed wire, chicken wire mesh, fitting, and tools, etc.) for Dullu, Dungeshwor and Mahabu R/M of Dailekh district.
- Package-II Fabricated materials (Iron works) for Dullu, Dungeshwor and Mahabu R/M of Dailekh district.

Surkhet District

- Package-III Various construction materials (HDPE Pipe, rebar, plain wire, barbed wire, chicken wire mesh, fitting, and tools, etc.) for Chinggad RM, Surkhet
- Package-IV Fabricated materials (Iron works) for Chinggad RM, Surkhet.

Achham District

- Package-V Various construction materials (HDPE Pipe, rebar, plain wire, barbed wire, chicken wire mesh, fitting, and tools, etc.) for Panchdewal Binayak & Kamalbazar R/M of Achham district.
- Package-VI Fabricated materials (Iron works) for Panchdewal Binayak & Kamalbazar R/M of Achham district.

Kalikot District

- Package-VII Various construction materials (HDPE Pipe, rebar, plain wire, barbed wire, chicken wire mesh, fitting, and tools, etc.) for Raskot & Shuvkalika R/M of Kalikot district.
- Package-VIII Fabricated materials (Iron works) for Raskot & Shuvkalika R/M of Kalikot district.

2. The eligible bidders may obtain further information about the requirements and clarity on the bid document at office address, phone number or email mentioned below. We will response to such a query during office hours (9 AM to 5 PM).
3. The bidders can download bidding documents from the Helvetas Nepal's website: www.helvetas.org/en/nepal/who-we-are/follow-us/public-announcements
4. Date of pre-bid meeting (online): **06 January 2023 at 2 PM**. Interested potential bidders can contact to water.np@helvetas.org on or before 12:30 PM by 06 January 2023 to participate the meeting.
5. Sealed bids must be submitted to the office address as follows:
Helvetas Nepal, Birendranagar-7, Itram, Surkhet
6. The last date for submission of sealed bid is on **17 January 2023** latest by **12 PM**.
7. The bids will be opened on **17 January 2023**, at **1 PM** in the presence of Bidder's representatives who choose to attend.
8. Bid security should be in a form of bank guarantee issued by "A" class commercial bank in favour of "**Water Resources Management Programme (WARM-P) Helvetas Nepal**", which is convertible into cash in Nepal without any condition (unconditional). The validity of bid security should be minimum **75 days** from the last date of bid submission.

The bid security amount is as follows:

Package-I : NRs 617,000 (in words: six hundred seventeen thousand only)

Package-II : NRs. 97,000 (in words: ninety-seven thousand only)

Package-III : NRs. 115,000 (in words: one hundred fifteen thousand only)

Package-IV : NRs. 22,000 (in words: twenty-two thousand only)

STANDARD BID DOCUMENT

Package-V : NRs. 229,000 (in words: two hundred twenty-nine thousand only)

Package-VI : NRs. 32,000 (in words: thirty-two thousand only)

Package-VII : NRs. 296,000 (in words: two hundred ninety-six thousand only)

Package-VIII : NRs. 63,000 (in words: Sixty-three thousand only)

9. The purchaser reserves the right to accept or reject any bid partially or fully without assigning any reasons whatsoever.

Helvetas Nepal

Birendranagar-7, Itam, Surkhet
Phone no: 083-521092, 083-521093,
Email: water.np@helvetas.org

STANDARD BID DOCUMENT

2. INSTRUCTIONS TO BIDDERS (ITB)

1. Scope of Works	1.1 The Purchaser stated in the Bid Data Sheet (BDS) for the procurement of Goods as detailed in attached specifications, drawings and the bill of quantities provided herein. The name of Purchaser, name of project and contract identification number of Contracts are provided in the Bid Data Sheet (BDS).
2. Eligible bidder	2.1 This Invitation for Bid is open to all registered local manufactures/suppliers. 2.2 Eligible and competent bidder must submit the following documents along with the bid. - documents as specified in EQC (4.1)
3. One bid per bidder	3.1 Each bidder shall submit only one bid, A bidder who submits more than one bids shall cause all the bids with the bidder's participation to be disqualified.
4. Site Visit	4.1 The bidder at his own cost, responsibility and risk may visit the site of the supply, delivery or installation of Goods and acquire all necessary information for preparing the bid and entering into a contract for the procurement of Goods.
5. Content of Bid	5.1 The bid document comprise the documents listed below: Section I: Invitation for Bids (IFB) Section II: Instructions to Bidders (ITB) Section III: Bid Data Sheet (BDS) Section IV: Evaluation and qualification criteria (EQC) Section V: Bid Forms and Price Schedule Section VI: Schedule of Requirements (SOR) Section VII: Specification and quality assurance. Section VIII: General Conditions of Contract (GCC) Section IX: Special Conditions of Contract Section X: Contract Form and formats Section XI: Annex
6. Clarification	6.1 A Prospective bidder may request clarification on the bidding documents in writing and the purchaser shall respond to such request. Clarification will be provided by purchaser 3 days before the last date of bid submission. 6.2 The purchaser may organize a pre-bid meeting of bidders before bid opening at the place, date and time as specified in the BDS to provide information relating to Bidding Documents and technical specifications. Interested bidder should obtain the bid document before pre-bid meeting.
7. Amendment of Bidding Document	7.1 At any time prior to the deadline for submission of the Bids, the Purchaser may amend the Bid Document by issuing addenda. 7.2 Any addendum issued shall be part of the Bidding Document and shall be communicated in writing to all who have obtained the Bidding Document directly from the Purchaser. Such Addendum notice shall also be published in the online/National newspaper.
8. Cost of bidding:	8.1 The Bidder shall bear all costs associated with the preparation and submission of its Bid, and the Purchaser shall not be responsible or liable for those costs, regardless of the conduct or outcome of the bidding process.
9. Language of Bids:	9.1 All correspondence and documents relating to the Bids shall be written in English or in Nepali language.
10. Alternative Bids	10.1 Alternative bids shall not be considered.

STANDARED BID DOCUMENT

11. Bidding price:	<p>11.1 All duties, taxes/transportation/loading/offloading/insurance, and other levies payable by the bidder under the contract shall be included in the rates, prices and total Bid Price submitted by the bidder.</p> <p>11.2 Price quoted by the bidder shall remain fixed and valid until completion of the Contract Performance and will not be subject to variation in any account.</p> <p>11.3 Bids and quoted rates shall remain valid for the period specified in the Bid Data Sheet. A bid valid for a shorter period shall be rejected by the purchaser as nonresponsive.</p> <p>11.4 If the purchaser determines the quoted rates of Bill of Quantity items by supplier are deviated unevenly leads to rejection of such bids as a nonresponsive.</p>
12. Unbalanced or Front/back-loaded bid	<p>12.1 If the purchaser found the item rates of the substantially lowest evaluated bid is seriously unbalanced or front-loaded or backloaded; may require the bidder to produce detailed price analysis for all items listed in price schedule of the bid document to demonstrate the price consistency of those rates with the authorized sources of the same.</p> <p>12.2 After the verification and assurance of the information and details of price analysis presented by the bidder, purchaser may accept or reject the bid.</p>
13. Currencies of Bid	<p>13.1 All prices shall be quoted in Nepalese Rupees.</p>
14. Bid validity	<p>14.1 1. Bid shall remain valid for a period specified in the BDS.</p>
15. Bid Security	<p>15.1 The bidder shall furnish as part of the bid, in original form, a bid security as specified in BDS.</p> <p>15.2 Bid security should be in a form of bank guarantee issued by "A" class commercial bank in favour of purchaser, which is convertible into cash in Nepal without any condition (unconditional) as specified in BDS.</p> <p>15.3 The bid security shall be returned upon request to unsuccessful bidder as soon as possible after formal contract signing.</p> <p>15.4 The Bid security shall be forfeited if the successful Bidder fails to:</p> <ul style="list-style-type: none"> – furnish a performance security, – sign the contract in accordance within the period stipulated in letter of award notification, – accept the correction of arithmetical errors, – provide the clarification of its bid by the date and time set in the purchaser's request for clarification.
16. Preparation of bid and submission	<p>16.1 The compiled and completed bid shall be sign and put bidder's stamp on every pages.</p> <p>16.2 The sealed envelope as per ITB 16.1 must reach within the deadline to purchaser's address specified in the BDS complying method of submission in the BDS. The envelope shall be addressed to the Purchaser as specified in the BDS and shall bear the name and identification number of the sealed bid.</p> <p>16.3 Unit rate in figures and words are not mentioned clearly in BOQ, it may lead to rejection and disqualification of the bid.</p>
17. Deadline for Submission of Bids:	<p>17.1 Bidding documents shall be sent to the Purchaser at the address no later than the time and date specified in the Bid Data Sheet (BDS).</p> <p>17.2 The Purchaser shall not consider any Bid that arrives after the deadline for submission of Bids. Any Bid received by the</p>

STANDARD BID DOCUMENT

	<p>Purchaser after the deadline for submission of Bids shall be declared late, rejected, and returned unopened to the bidder.</p> <p>17.3 Bidding document once submitted shall not be withdrawn or modified.</p> <p>17.4 If the last date of purchasing, submission, and opening falls on a Helvetas Nepal holiday then the next working day shall be considered the last day.</p>
18. Bid Opening:	<p>18.1 The Purchaser shall open the bids in the presence of the bidders' representatives who choose to attend at the time and in the place as specified in the Bid Data Sheet (BDS).</p> <p>18.2 The Purchaser shall prepare minutes of the opening including the information disclosed to those present.</p>
19. Process to be Confidential:	<p>19.1 Information relating to the evaluation and comparison of Bids and recommendations for the award of a contract shall not be disclosed to bidders or any other persons not officially concerned with such process until the award to the successful bidder has been announced.</p> <p>19.2 Any efforts by the bidder to influence the Purchaser in the Bid evaluation, comparison or contract award decisions may result in rejection of bidder's Bids.</p>
20. Evaluation criteria:	<p>20.1 The purchaser shall evaluate the bid in accordance with set criteria as specified in the evaluation and qualification criteria (EQC).</p>
21. Evaluation and Comparison of bids:	<p>21.1 In evaluating the bids, the Purchaser shall determine for each bid the evaluated bid price by adjusting any corrections for errors. Bids shall be checked by the Purchaser for any arithmetic errors. Errors shall be corrected by the Purchaser as follows:</p> <p>21.2 If there is a discrepancy between the unit price and the total price that is obtained by multiplying the unit price and quantity, the unit price shall prevail, and the total price shall be corrected.</p> <p>21.3 If there is an error in a total corresponding to the addition or subtraction of subtotals, the subtotals shall prevail, and the total shall be corrected.</p> <p>21.4 If there is a discrepancy between words and figures, the amount in words shall prevail, unless the amount expressed in words is related to an arithmetic error, in which case the amount in figures shall prevail.</p> <p>21.5 If the purchaser determines the quoted rates of BoQ items by supplier are deviated unevenly leads to rejection of such bids.</p> <p>21.6 While quoting rates, the bidder shall not be allowed to use correcting fluid or other erasing materials; neither the bidder shall be allowed to overwrite the quoted rates. It may result to rejection of the bid document. In case of mistakes in rates, the bidder is to simply cross the rates and shall re-write the rates and shall bear the initials of authorized signatories and company/firm's stamp.</p>
22. Notification of Award and contract signing	<p>22.1 The purchaser shall award the contract to the bid as per bid data sheet.</p> <p>22.2 The successful bidder shall deliver the performance security as specified in SCC.</p> <p>22.3 If the successful bidder fails to deliver the Performance Security and sign the contract within specified time, the purchaser holds right to award the contract to next lowest evaluated substantially responsive bid or decide as per purchaser's convenience.</p>

STANDARD BID DOCUMENT

23. Performance Security	<p>23.1 Within deadline of the receipt of Letter of Acceptance from the purchaser, the successful bidder shall furnish the performance security in a form of Bank Guarantee from "A" class commercial bank acceptable to the purchaser.</p> <p>23.2 The proceeds of the performance security shall be payable to the purchaser as compensation for any loss resulting from the supplier's failure to complete its obligations under the Contract.</p> <p>23.3 The amount of performance security will be according to BDS.</p>
24. Goods Delivery:	<p>24.1 The bidders should make delivery of ordered quantities in place and time as per clause 6.1 of the bid document under Schedule of Requirement (SoR).</p> <p>24.2 All the delivered materials must comply the quality and specification mentioned in the specification section of this bid document. The supplier must ensure the proper packing and safeguarding from damage of goods during supply.</p>
25. Payment:	<p>25.1 Payment will be made upon receiving materials along with the valid tax invoice and successful delivery evidence.</p> <p>25.2 Payment can be made full or partial as per convenience of purchaser.</p>
26. Format and signing of bids:	<p>26.1 The Bid shall be typed or written in indelible ink and shall be signed by an authorized person. Any entries or amendments including alternations, additions or corrections made shall be initialed by the same authorized person.</p>
27. Joint Venture	<p>27.1 Joint venture (JV) bids shall not be considered.</p>
28. Purchaser's Right to Accept or Reject	<p>28.1 The Purchaser reserves the right to accept or reject any Bid or to cancel the bidding process and reject all Bids, at any time prior to the award of the contract, without assigning any reasons whatsoever and without thereby incurring any liability to the affected bidder or bidders.</p>
29. Confusing Specification	<p>29.1 If the parameters of the specification are confused, manufacturer's certificate (origin of certificate) will prevail.</p>
30. National product	<p>30.1 We encourage/promote national products if equally qualified with the international product.</p>
31. Corrupt or Fraudulent practices	<p>31.1 The purchaser shall reject the bid for award if it determines that the Bidder recommended for award of contract has engaged in corrupt or fraudulent practices in competing for the contract in question.</p>

STANDARD BID DOCUMENT

3. BID DATA SHEET (BDS)

ITB 1	<p>The scope of bid is to supply and delivery of Package-IV Fabricated materials (Iron works) for Chinggad RM, Surkhet</p> <p>The number of the Invitation for Sealed bid is: IWRM/04/2023</p> <p>The Purchaser: Integrated Water Resources Management Programme Helvetas Nepal, Surkhet.</p>
ITB 6	<p>The pre-bid meeting shall be conducted in the following:</p> <p>Date : 06 Jan 2023</p> <p>Time : 02:00PM</p> <p>Place : Online-Microsoft team</p>
ITB 14	<p>Bids and quoted rate shall be valid at least 45 days from the date of bid submission.</p> <p><i>It can be extended for further period if both parties are agreed.</i></p>
ITB 15	<p>Beneficiary name for bid security: Water Resources Management Programme (WARM-P), Helvetas Nepal, Surkhet</p> <p>The bid must be accompanied by bid security, amounting to a minimum of NRs. 22,000 (in words: twenty-two thousand only), the validity of bid security should be minimum 75 days from the last date of bid submission.</p>
ITB 17	<p>The deadline for sealed bid submission is:</p> <p>Address: Helvetas Nepal, Itam, Birendranagar, Surkhet</p> <p>Date: 17 January 2023</p> <p>Time: Before 12: 00 PM</p>
	<p>Method of bid submission: The bidder must submit the sealed bid in the following method:</p> <p>Method: Hard copy submission (only sealed hard copy envelope is accepted)</p>
ITB 18	<p>The bid opening schedule:</p> <p>Address: Helvetas Nepal, Itam, Birendranagar, Surkhet</p> <p>Date: 17 January 2023</p> <p>Time: 1:00 PM</p> <p>The Purchaser shall open the bids at scheduled date, time and place. Bidders or their representatives are encouraged to participate in the bid opening event.</p>
ITB 22.1	<p>The contract shall be awarded to lowest evaluated substantially responsive bid.</p>
ITB 23	<p>The performance security: 10% of total contract price with minimum validity of 120 days from the award notice.</p>

4. EVALUATION AND QUALIFICATION CRITERIA (EQC)

The required form and documents shall be part of technical bids.

SN	Particulars	Requirements
1	Copy of firm/company registration certificate	Mandatory
2	Copy of VAT registration certificates	Mandatory
3	Copy of tax clearance certificate for the fiscal year 2078/079	Mandatory
4	Original copy of bid security	Mandatory
5	Has been properly signed by the authorized person as per ITB 16.1	Mandatory
6	Completed price schedule as per ITB 16.3	Yes/No
7	Use of correction fluid/overwrite. (if yes, authorized signature and stamp is needed)	Yes/No

5. BID FORM AND PRICE SCHEDULE

5.1 LETTER OF BID

**To: Integrated Water Resources Management Programme
Helvetas Nepal
Surkhet**

We, the undersigned, declare that:

- a) We have examined and have no reservations to the Bidding Documents.
- b) We offer to execute in conformity with the Bidding Documents the following Works:
- c) **The total price of our Bid, excluding any discounts offered in item (d) below is:**
- d) **The discounts offered in this bid is :..... (discount offer other than in this section will not be accepted. Such a discount offer should be mentioned either percentage or in figure clearly).**
- e) Our bid shall be valid for a period of **45 days** from the date fixed for the bid submission deadline in accordance with the Bidding Documents, and it shall remain binding upon us and may be accepted at any time before the expiration of that period.
- f) If our bid is accepted, we commit to obtain a performance security in accordance with the Bidding Document.
- g) We understand that this bid, together with your written acceptance thereof included in your notification of award, shall constitute a binding contract between us, until a formal contract is prepared and executed.
- h) We declare that we have not been blacklisted and no conflict of interest in the proposed procurement proceedings and we have not been punished for an offense relating to the concerned profession or business.**
- i) We understand that you are not bound to accept the lowest evaluated bid or any other bid that you may receive; and
- j) If awarded the contract, the person named below shall act as contractor's representative:
- k) If awarded the contract, contractor respect and comply the purchaser's code of conduct unless violating the prevailing rules of Government of Nepal.
- l) We agree to permit the Employer or its representative to inspect our accounts and records and other documents relating to the bid submission and to have them audited by auditors appointed by the purchaser.

Authorized signature: _____

Name _____

In the capacity of _____

Company Name _____

Company Seal/stamp: _____

Date: _____



Handwritten signature

STANDARD BID DOCUMENT

5.2 BIDDER'S INFORMATION FORM

[The bidder shall fill in the following Form. No alterations to its format shall be permitted and no substitutions shall be accepted.]

1.	Bidder's Legal Name	
2.	Bidder's Address:	
3.	Bidder's Country of Registration:	Nepal
4.	Bidder's Year of Registration:	
5.	Bidder's Authorized Representative Information: Name: Address: Telephone/Fax numbers: Email Address:	
6.	Bidder's Telephone/Fax numbers:	
7.	Bidder's Email Address:	

5.3 PRICE SCHEDULE:

Sn	Materials Name	Unit	Quantity	Rate in NRs. (Including transportation/loading/offloading/insurance etc. cost)		Amount	Remark
				In Figure	In Words		
1	Angle Pole	No	95				
2	Angle Pole for Gate	No	44				
3	Angle Pole for Corner	No	88				
4	Angle Pole for Bracing	No	148				
5	Angle Gate	No	22				
6	Square Slab Frame (Small)	No	11				
7	Square Slab Frame (Big)	No	47				
8	Square Slab Frame (Big) with Metal Cover	No	10				
9	Iron Bracket 1/2"	Pc	5				
10	Iron Bracket 1-1/4"	Pc	1				
11	Iron Bracket 2-1/2"	Pc	1				
12	Tool box (empty)	Pc	4				
13	Slab frame key	Pc	20				
14	Tapstand Grid	No	9				

STANDARD BID DOCUMENT

Sn	Materials Name	Unit	Quantity	Rate in NRs. (Including transportation/loading/offloading/insurance etc. cost)		Amount	Remark
				In Figure	In Words		
15	Information Board	Set	4				
Total Amount							
VAT 13%							
Grand Total							
in words :							
.....							

Authorized signature: _____

Name: _____

Designation: _____

Company Seal/stamp: _____

Date: _____



6. SCHEDULE OF REQUIREMENTS (SOR)

The purchaser will strictly monitor that the schedule of requirements is fully honored by the supplier and shall assess the performance of the supplier in view of adherence to it.

6.1 DELIVERY PLACE AND SCHEDULE

The goods shall be delivered in the following manner:

Sn	Scheme's Name	Delivery Place	Estimated distance	Delivery Schedule in days after signing the contract agreement
1	Chinggad Rural Municipality (3DWS)	Thatibazar	about 55km from Birendranagar, Surkhet	60 Days
2	Chinggad Rural Municipality (Gogane DWS)	Dhandkhet	about 60km from Birendranagar, Surkhet	60 Days

6.2 NOTICE OF DELAY

In the event that the Supplier encounters a delay in supply of the goods, the Supplier shall promptly notify the Purchaser of such delay with proper evidence and may request for time extension before expiry of the time given in the contract.

6.3 TIME EXTENSION

Time extension request shall be considered by the Purchaser only in exceptional case if the reasons are acceptable to the Purchaser.

6.4 PENALTIES FOR DELAY

In case of delay in the delivery of the goods, due to Supplier's default, beyond the time specified in the contract, the penalty will be determined as per the conditions of contract.

6.5 EMPLOYMENT

The Supplier shall employ exclusively local skilled/unskilled labours. Helvetas Nepal requires that tender, contractors and suppliers ensure during the procurement and execution of such contracts that people in the supply-chain are treated with respect and have rights with regard to employment including the rights to freely choose employment, freedom of association, payment of a living wage, working hours that comply with national laws, equal opportunities, recognized employment relationship, freedom from intimidation and to a safe and healthy working environment. Equally, contractors must ensure that there shall be no exploitation of child and forced labour. This shall be ensured in terms of the ILO Convention No. 182 on the Worst Forms of Child Labour, 1999 and the ILO Convention No. 138 on the Minimum Age for Admission to Employment and Work, 1973.

6.6 GENDER

No discrimination for wage payment will be made on the basis of gender or caste or ethnicity.

6.7 EQUITY

The Supplier shall pay equal wage for equal work.

6.8 INSURANCE

The supplier shall procure insurance policy for all the personnel working in supply of goods.

7. SPECIFICATIONS & QUALITY ASSURANCE

7.1 QUALITY OF MATERIALS

The materials supplied and used in the works shall comply with the requirements of these Specifications. The materials/goods shall be manufactured, handled and used skillfully to ensure completed works to comply with the contract.

TECHNICAL SPECIFICATION

SN	Name of goods and related services	Required Specification
1	Angle pole	Steel angle size 40mm x 40mm x 5mm; length 200cm. Black Japan paint coated after red oxide coat. Nos. of holes & spacing as per attached drawing. Smooth finishing, as per attached drawing
2	Angle pole for gate	Steel angle size 40mm x 40mm x 5mm; length 200cm. Black Japan paint coated after red oxide coat. Nos. of holes & spacing as per attached drawing. Smooth finishing, as per attached drawing
3	Corner Pole	Steel angle size 40mm x 40mm x 5mm; length 200cm. Black Japan paint coated after red oxide coat. Nos. of holes & spacing as per attached drawing. Smooth finishing, as per attached drawing
4	Bracing Pole	Steel angle size 40mm x 40mm x 5mm; length 190cm. Black Japan paint coated after red oxide coat. Nos. of holes & spacing as per attached drawing. Smooth finishing, as per attached drawing
5	Angle Gate	Steel angle size 40mm x 40mm x 3mm Black Japan paint coated after red oxide coat. Steel bar spacing and design as per attached drawing. Smooth finishing & excellent welded joint, as per attached drawing
6	Tap stand Grid	Size 18cm x 25 cm; plate thickness 2mm and breadth 20mm, Black Japan paint coated after red oxide coat. Design and spacing as per attached drawing, Smooth finishing & excellent welded joint, as per attached drawing
7	Square Slab Frame (750x750mm inner size) Big Slab Frame Type I	Outer & inner square frames, Outer for fixing and Inner removable, Male outer frame size: 81.5x81.5 cm & Female outer frame size: 84.0x84.0cm, Steel angle size 40mm x 40mm x 3mm, Black Japan paint coated after red oxide coat, Smooth finishing & excellent welded joint, as per attached drawing.
8	Square Slab Frame (550x550mm Inner size) Small Slab Frame Type II	Outer & inner square frames, Outer for fixing and Inner removable, Male outer frame size: 61.5x61.5 cm & Female outer frame size: 63.0x63.0cm, Steel angle size 40mm x 40mm x 3mm, Black Japan paint

SN	Name of goods and related services	Required Specification
		coated after red oxide coat, Nos. of holes & spacing as per attached drawing. Smooth finishing & excellent welded joint, as per attached drawing
9	Slab Frame Key	Made of best quality 10mm MS plain bar, Black Japan paint coated after red oxide coat, Smooth finishing, as per attached drawing.
10	Information Board	Size – 3 ft × 4ft, Sheet – 20 gauge (black iron sheet) Angle frame – 25mm×25mm×3mm Vertical Support: 32 mm dia. Or 1¼” GI Pipe (MC) Length of support/32mm dia GI Pipe: 10 ft 2 nos
11	Toolbox with tray	Size 600×280×280mm minimum, with lock Material: 1mm thick steel plate, blue enamel painted, locally made
12	Bracket	as per provided sample
13	Square Slab Frame (750x750mm) with Metal Cover	Outer & inner square frames, outer for fixing and inner removable, Male outer frame size: 81.5x81.5 cm & Female outer frame size: 83.0x83.0cm, Steel angle size 40mm x 40mm x 3mm, Metal frame 85.0cm x 85.0cm x 0.2cm Black Japan paint coated after red oxide coat, Smooth finishing & excellent welded joint, As per attached drawing.

Drawings

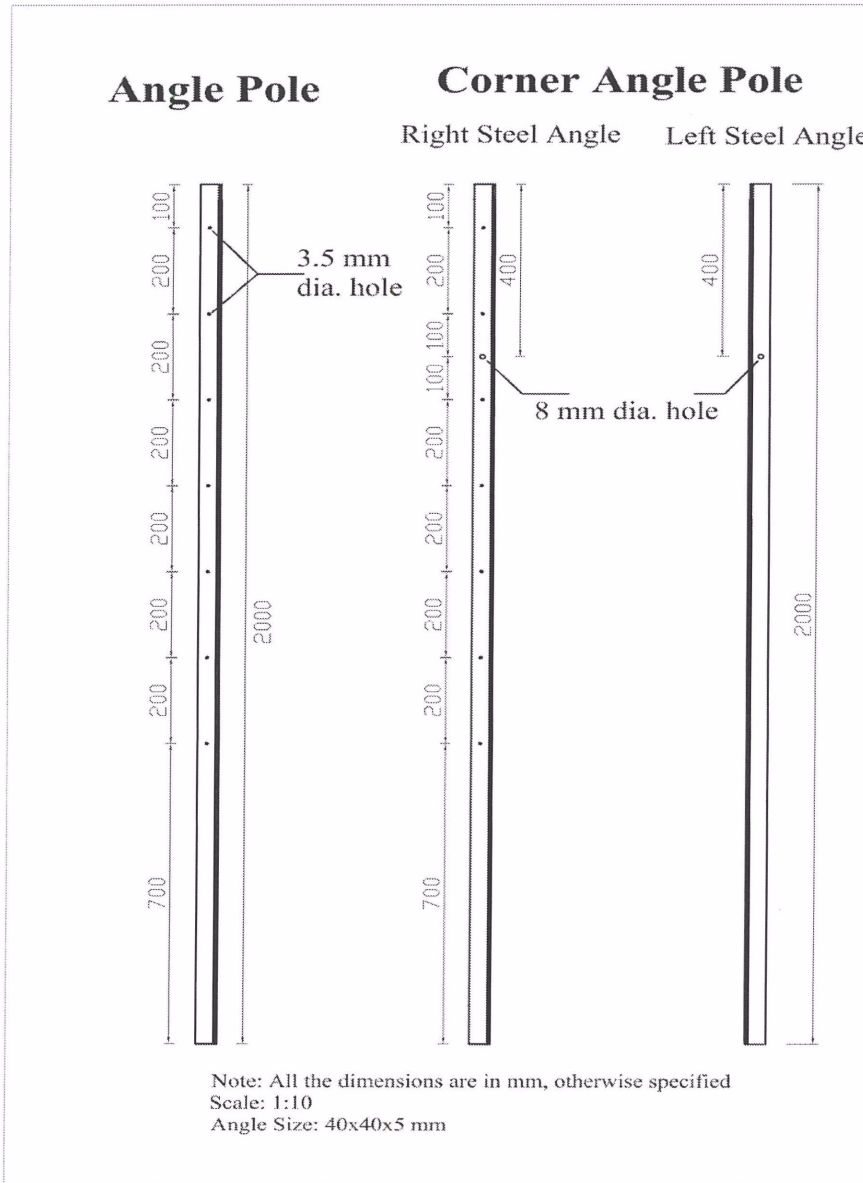

Bracing Angle Pole

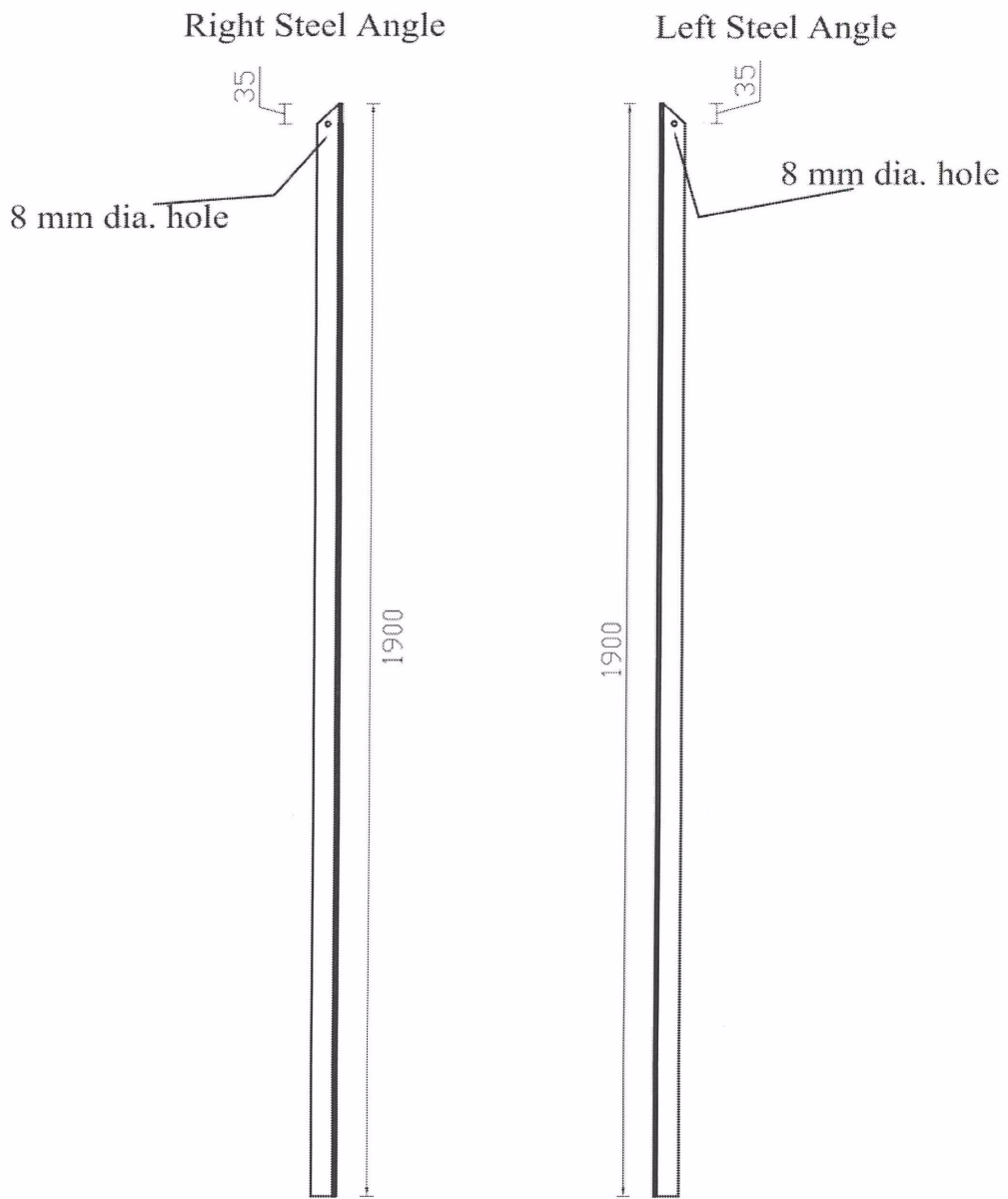

Note: All the dimensions are in MM, otherwise specified
Scale: 1:10
Angle Size: 40x40x5 mm

Angle Gate

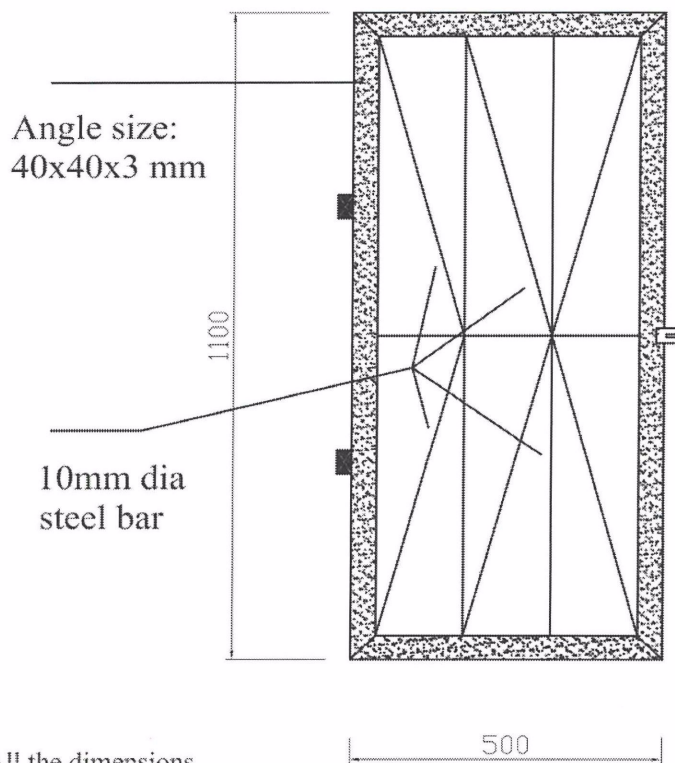
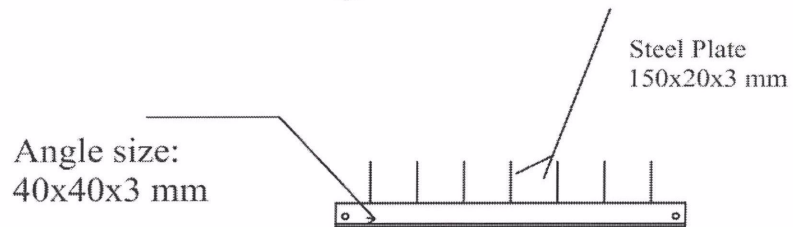

Note: All the dimensions are in MM, otherwise specified

Scale: 1:10

Assembly of Angle Gate

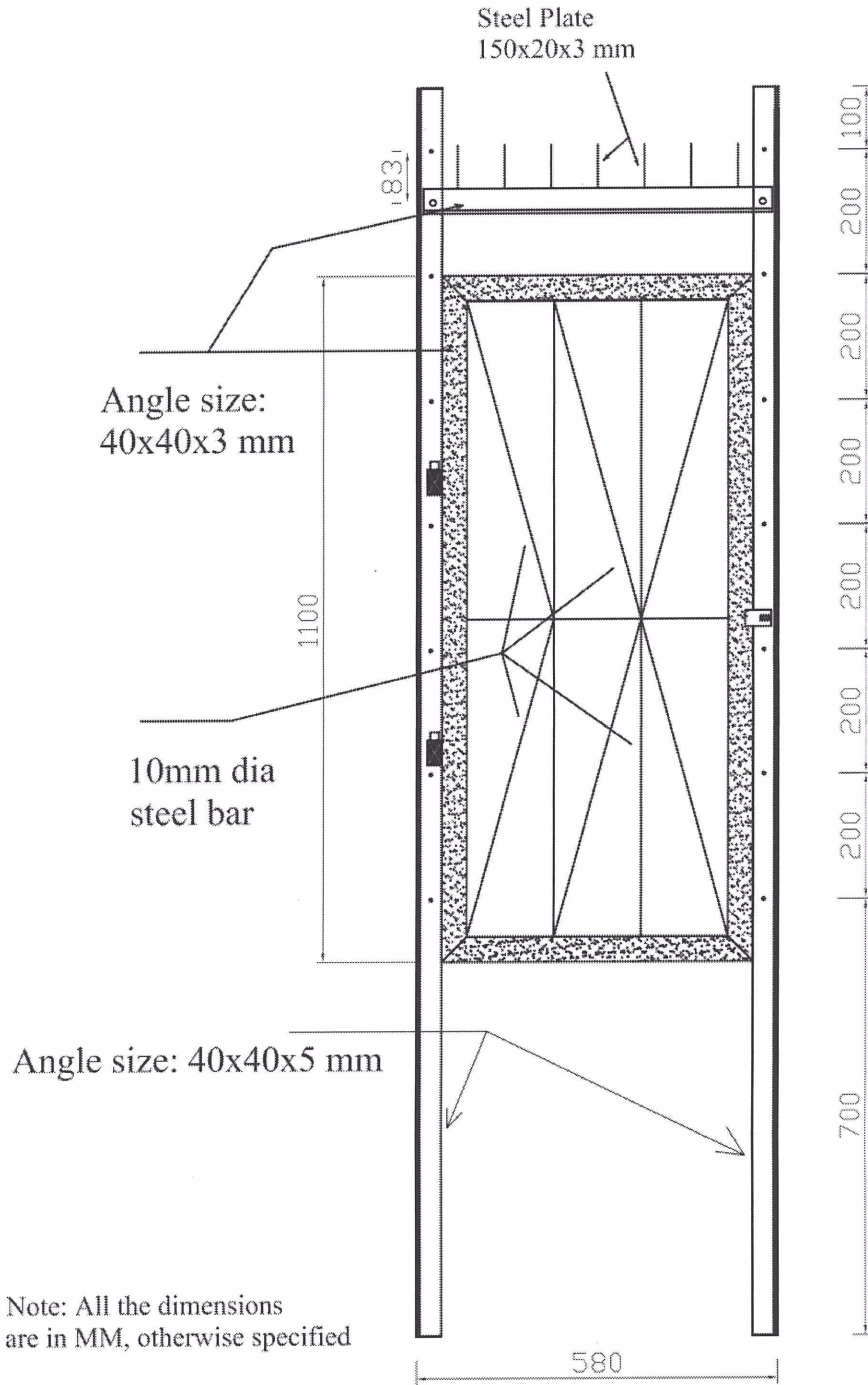

Square Slab Frame (Small)

Outer Frame
Angle Size: 40x40x3 mm

Inner Frame
Angle Size: 40x40x3

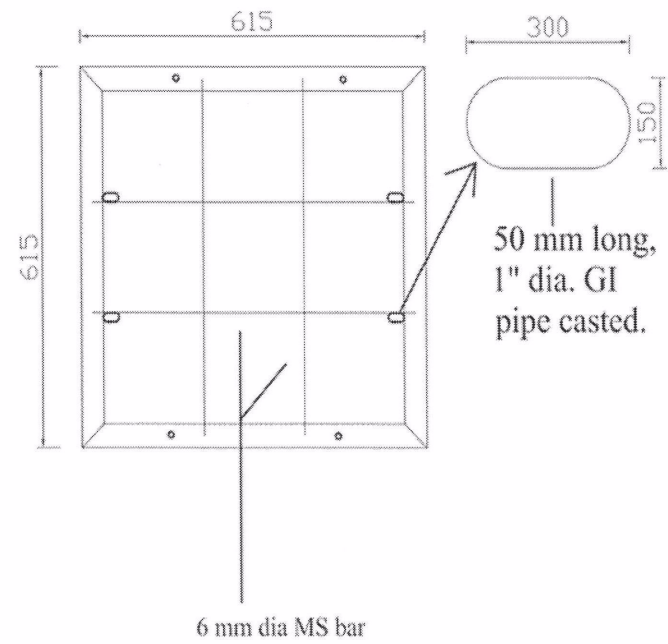
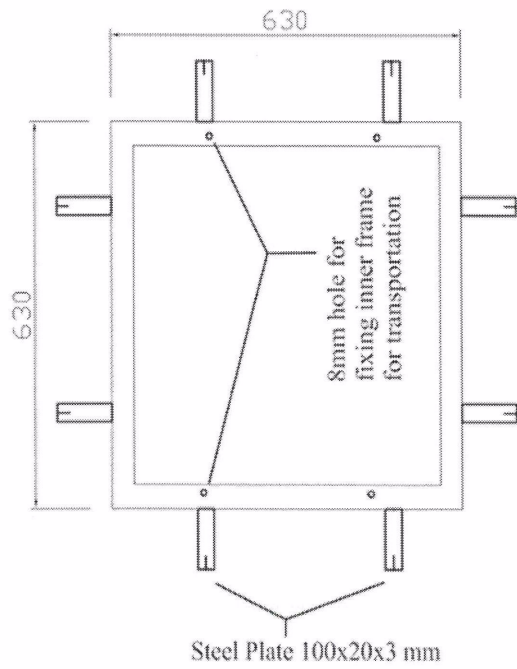

Note: All the dimensions are in mm, otherwise specified
Scale: 1:10

Square Slab Frame (BIG)

Outer Frame
Angle Size: 40x40x3 mm

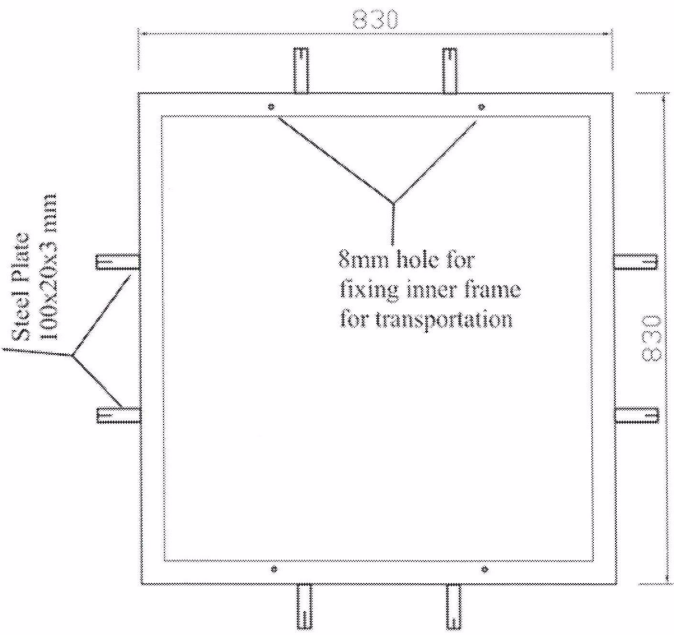

Inner Frame
Angle Size: 40x40x3

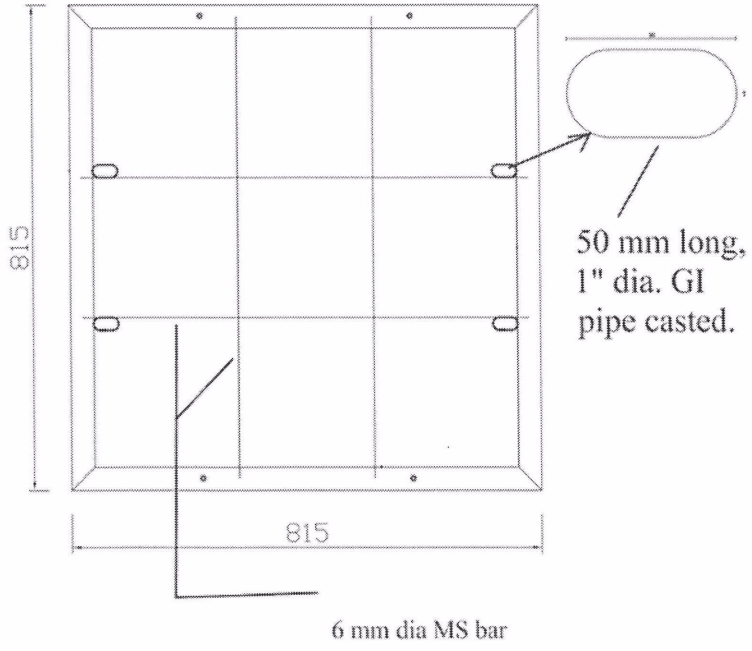

Note: All the dimensions are in mm, otherwise specified

Scale: 1:10

Tap Stand Grid

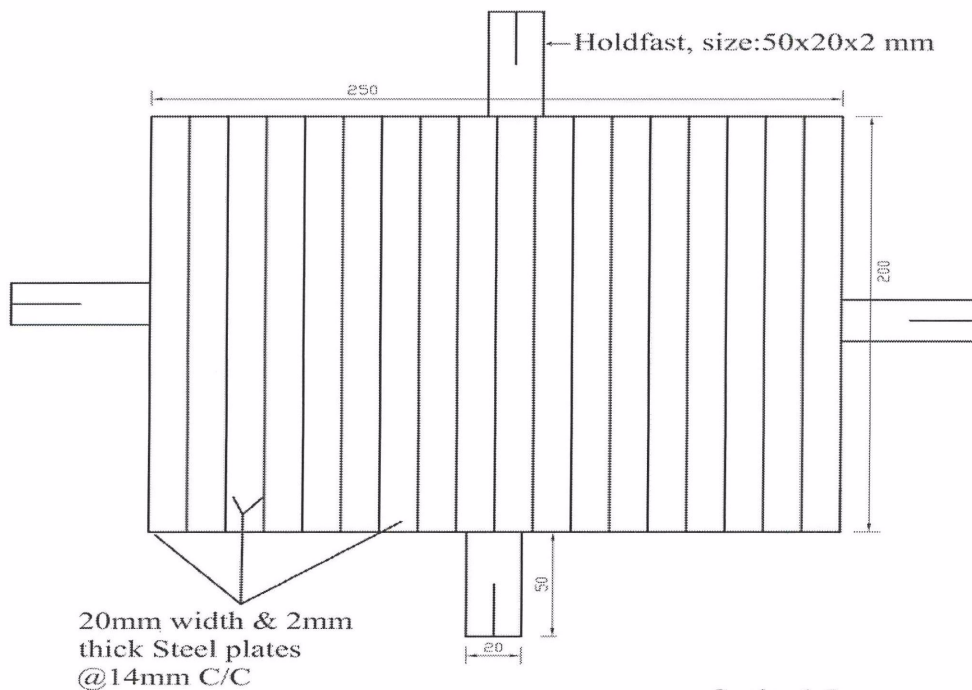

Iron Bracket 1/2" & 3/4"

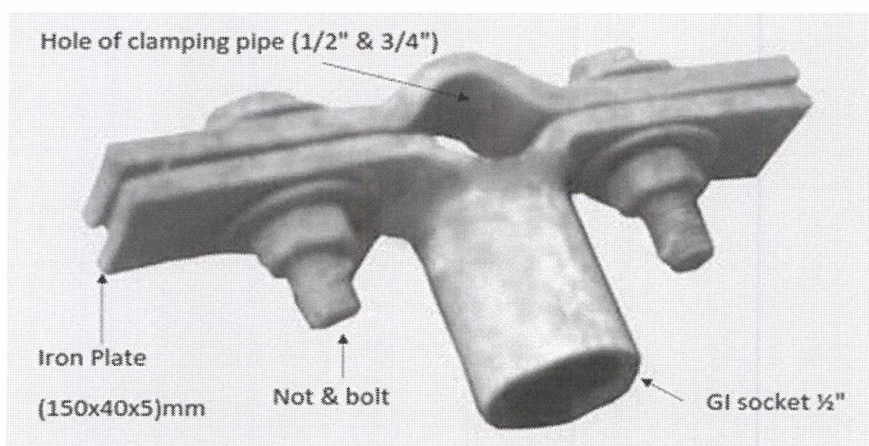

Slab Frame Key

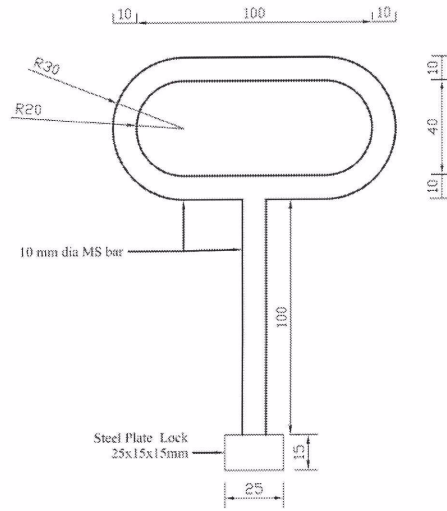

Scale: 1:2

Top View of Steel Plate Lock

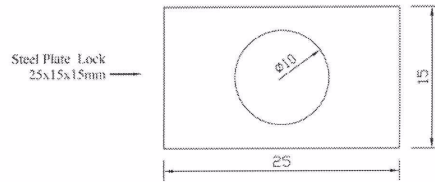

Note: Not to the scale

Note: All the dimensions are in mm otherwise specified.

Square Slab Frame (750x750mm) with Metal Cover

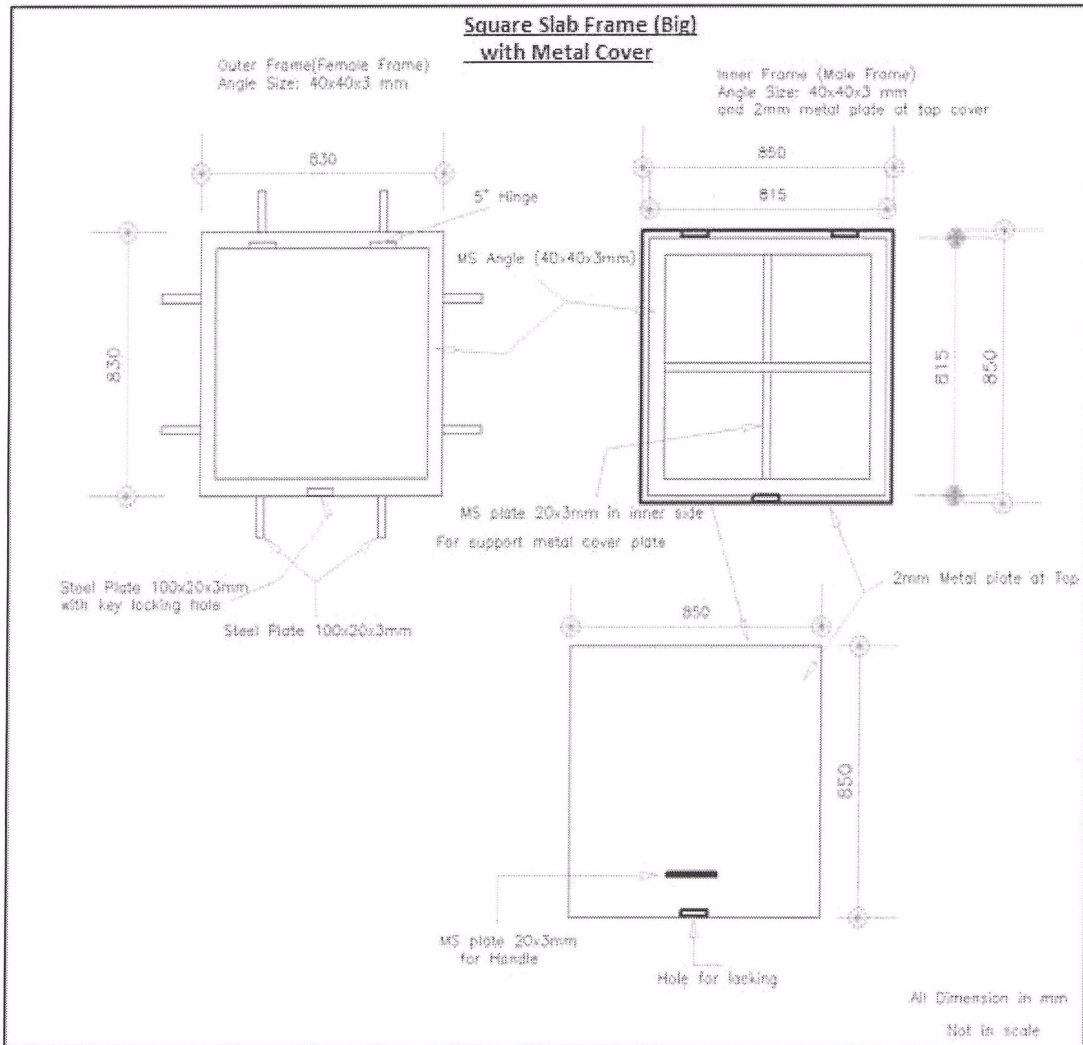

7.2 SOURCES OF MATERIALS

The use of any one kind or class of material from the source is to be approved. The sources or kinds of material shall not be changed without written permission of the Engineer. If the product of any source proves unacceptable, the supplier shall make necessary arrangements for the supply of acceptable material. Any claims for compensation associated with such arrangements or changes shall not be considered, unless the source of the unacceptable material is designated in the contract as a source of material.

7.3 QUALITY REQUIREMENTS, QUALITY CONTROL AND QUALITY ASSURANCE (GUARANTEE)

The quality control of the materials acquired, is the responsibility of the prime Supplier, who should guarantee that all materials are of standard quality according to the specifications given are correct according to Design and Drawings. The cost for all damages due to use of low-quality materials has to be borne by the Supplier. At the time of delivery, the parts and materials shall have to be free from any defects in material or workmanship in all respects and shall remain reasonably perfect till the end of maintenance period when a final check shall be carried out.

7.4 INSPECTION, TESTS AND FINAL CHECK

The Supplier shall coordinate to provide access and other facilities for the inspection and, if required, tests of the materials. Such inspection shall be made prior to delivery or at time of delivery at destination and shall be conducted so as not to interfere unnecessarily with the operation of other work. Such inspections are supplementary and intended to clear the delivery only and shall not be considered as a final acceptance.

The final check of all materials will be conducted, and the discrepancies found during such final check have to be rectified by the supplier at its own cost. On a default situation, such works shall be conducted by the Purchaser and the cost incurred for such works shall be made a liability in the supplier's account (either from other payments and/or their property according to the prevailing rules and regulations).

The inspector may at his/her discretion check the test results obtained at the Supplier's works by independent tests and should the material so tested be found to be unsatisfactory, the costs of such tests shall be borne by the supplier, and, if satisfactory, the costs shall be borne by the Purchaser. In any case the quality assurance by the Supplier has to be made available, whenever required by the Purchaser.

7.5 TRANSPORTATION

It is the responsibility of the Supplier to control transportation activities and quality/quantity of any materials, loading and off-loading of the same, and the delivery at designated point. The Supplier shall entirely be responsible for the quality and quantity of materials received at the point of origin and their delivery at designated point in the same quantity and quality. No reasons whatsoever will be accepted for materials not reaching to site in proper condition and in required quantity. Loss during transportation, if any is entirely on the Supplier's account. Work being delayed because of materials being damaged during transportation is Supplier's concern, which shall not be considered a reason for the time extension.

7.6 HEALTH AND SAFETY

The handling staff from supplier shall be equipped with application of full safety equipment's such as gloves and sturdy boots to prevent injury, and that a first aid package is available at loading and off-loading locations

8. GENERAL CONDITIONS OF CONTRACT (GCC)

- 1. Definitions**
- 1.1 In this contract, the following terms shall be interpreted as indicated:
- a. "The Contract" means the agreement entered between the Purchaser and the Supplier and signed by both the parties and it includes all attachments and appendices thereto and all documents incorporated by reference therein.
 - b. "The Contract Price" means the price payable to the Supplier under the contract for the full and proper performance of its contractual obligation.
 - c. "The Goods" means Equipment and related Accessories and spare-parts or any other materials which the Supplier is required to supply to the Purchaser under the contract.
 - d. "The Services" means the works described in the Terms of References to be performed by the supplier including modification, alteration, and additions of works and other obligations of the supplier covered under the Contract.
 - e. "The Purchaser" means the procuring entity purchasing the goods.
 - f. "The Supplier" means the organization supplying the goods and services under this contract.
 - g. "Engineer" or "The purchaser's representative" means the engineer appointed by the purchaser from time to time for inspection/supervision of goods and services.
 - h. "The Delivery Site" means the place or places where delivery of the goods is to be made. It is also to be referred as "destination point".
 - i. "Terms of Reference" means the schedule of works and duties, defined by the bidding document and to be executed by the supplier under this contract.
- 2. Application** These General Conditions shall apply to the extent that they are not superseded by provisions in other parts of the contract.
- 3. Standards**
- 3.1 The Goods supplied under this Contract shall conform to the standards mentioned in the **Technical Specifications**,
- 3.2 Wherever reference is made in the **Technical Specifications** to specific standards and codes to be complied with, the specified standards and codes shall apply and the provisions of the latest edition or revision of the standards or codes shall apply only with the pre-consent of the Purchaser.
- 4. Use of Contract Documents and Information**
- 4.1 The Supplier shall not, without the Purchaser's prior written consent, disclose the Contract, or any provision thereof, or any specification, plan, drawing, pattern, sample, or information furnished by or on behalf of the Purchaser to any person other than a person employed by the Supplier for performing the Contract. Disclosure to any such employed person shall be made in confidence and shall extend only so far as may be necessary for purposes of such performance.
- 4.2 The Supplier shall not, without the Purchaser's prior written consent, make use of any document or information except for purposes of performing the Contract.
- 4.3 Any document, other than the Contract itself, shall remain the property of the Purchaser and shall be returned (all copies) to the

- Purchaser on completion of the Supplier's performance under the Contract, if so, required by the Purchaser.
- 5. Patent Rights** The Supplier shall indemnify the Purchaser against all third-party claims of infringement of patent, trademark, or industrial design rights arising from use of the Goods or any part thereof.
- 6. Inspections and Tests**
- 6.1 The Purchaser or its Representative shall have the right to inspect and/or to test the goods at its own costs. The Purchaser shall notify the Supplier in writing of the identity of any representatives retained for these purposes.
- 6.2 The inspections and tests can be conducted on the premises of the Supplier or its sub-Supplier(s) and/or at the Goods' destination. If conducted on the premises of the Supplier or its sub-Suppliers(s), all reasonable facilities and assistance, including access to drawings and production data, shall be furnished to the inspectors at no charge to the Purchaser.
- 6.3 Any inspected or tested Goods fail to conform to the Specifications, the Purchaser may reject the Goods, and the Supplier shall either replace the rejected Goods or make alternations necessary to meet specification requirements, free of cost to the Purchaser.
- 6.4 Nothing in GCC shall in any way release the Supplier from any warranty or other obligations under this Contract.
- 6.5 A Certificate of Acceptance shall be issued by the Purchaser after necessary inspection and tests of the Goods in case the goods conform to the specifications and drawings.
- 7. Packing**
- 7.1 The Supplier shall provide such packing of the Goods as is required to prevent their damage or deterioration during transit to their destination, as indicated in the Contract. The packing shall be sufficient to withstand, without limitation, rough handling during transit and exposure to extreme temperatures, salt and precipitation during transit, and open storage. Packing case size and weights shall take into consideration, where appropriate, the remoteness of the Goods' destination and the absence of heavy handling facilities at all points in transit.
- 7.2 The packing, marking and documentation inside and outside the packages shall comply strictly with such special requirements as delineated instructed by the Purchaser.
- 8. Insurance** The goods supplied under this Contract shall be fully insured against loss or damage incidental to manufacture or acquisition, transportation, storage, and delivery. Such insurance shall be arranged and paid for by the supplier.
- 9. Transportation**
- 9.1 The Supplier shall be required to meet all transport and storage expenses until delivery.
- 9.2 Transportation of the goods after delivery at the destination point shall be the responsibility of the Purchaser
- 10. Incidental Services** The Supplier may be required to provide incidental services, including additional services, if any.
- 11. Warranty**
- 11.1 The Supplier warrants that the Goods supplied under the Contract are new and unused. The Supplier further warrants that all Goods supplied under this Contract shall have no defect, arising from design, materials, or workmanship or from any act or omission of the Supplier.
- 11.2 The warranty shall remain valid for (12) months after the delivery of the goods at the destination point indicated in the Contract to the satisfaction of the Purchaser.

In case any defect is observed or found in the goods at the site, the supplier shall be liable to bring back the defective goods and shall replace them with proper ones at his/her own costs.

- 11.3 The Purchaser shall promptly notify the Supplier in writing of any claims arising under this warranty.
- 11.4 Upon receipt of such notice, the Supplier shall, within the period specified and with all reasonable speed, repair or replace the defective Goods or parts thereof, without costs to the Purchaser.
- 11.5 If the Supplier, having been notified, fails to take remedial action within fifteen (15) days from date of receipt of notice, the Purchaser may proceed to take such action as may be necessary, at the Supplier's risk and expense and without prejudice to any other rights which the Purchaser may have against the Supplier under the Contract.
- 12. Payment and Taxes**
- 12.1 After acceptance of the goods by the purchaser and their delivery at the destination point, payments shall be made by the Purchaser, within 15 days. The full and final payment shall be made only after completion of delivery. The purchaser may consider part payment based on delivery upon request of the supplier and if deemed essential on mutual understanding.
- 12.2 All taxes applicable shall be for the Supplier's account.
- 12.3 VAT shall be explicitly mentioned on the invoice and shall be for the Purchaser's account.
- 13. Prices**
- 13.1 Prices charged by the Supplier for goods under the Contract shall not vary from the prices quoted by the Supplier in its bid.
- 14. Order Placement**
- 14.1 The Purchaser may place the order on lot basis in a written form to the suppliers.
- 14.2 Actual contract size, quantity, duration etc. can be done in accordance with clauses of contract (refer SCC).
- 14.3 The order size will be confirmed at the time of order placement. (refer SCC).
- 14.4 Additional order: the purchaser can place order for additional quantity within price validity period under this agreement if required.
- 15. Contract Amendments**
- 15.1 Duration of contract may be extended by mutual understanding without affecting the agreed quality and cost.
- 15.2 Price validity of original contract may be extended by mutual understanding of contracting parties.
- 16. Assignment**
- The Supplier shall not assign to a third party, in whole or in part, its obligations to perform under the Contract, except with the Purchaser's prior written consent.
- 17. Subcontracts**
- The Goods/Services shall be fully supplied/performed by the Supplier and shall strictly abstain from sub-contracting in whole or any portion of the goods/services to any other supplier other than other than the partners mentioned in Bid Form.
- 18. Delays in the Supplier's Performance**
- 18.1 Delivery of the goods and performance of services shall be made by the Supplier in accordance with the time schedule specified by the Purchaser in the **Schedule of Requirement**.
- 18.2 An unexcused delay by the Supplier in the performance of its delivery obligations shall render the Supplier liable to any or all of the following sanctions: imposition of liquidated damages, termination of the Contract and /or disqualification up to a period of two years.
- 18.3 If at any time during performance of the Contract, the Supplier should encounter conditions impeding timely delivery of the

goods and performance of Services, the Supplier shall promptly notify the Purchaser in writing of the fact of the delay, its likely duration and its cause(s). As soon as practicable after receipt of the Supplier's notice, the Purchaser shall evaluate the situation and may, at its discretion, extend the Supplier's time for performance, with or without liquidated damages.

19. Liquidated Damages

If the Supplier fails to deliver any or all of the goods or to perform within the time period(s) specified in the Contract, the Purchaser shall, without prejudice to its other remedies under the Contract, deduct from the Contract Price, as liquidated damages, a sum equivalent to 0.25% of the contract price of the delayed goods for each day of delay until actual delivery, up to a maximum deduction of (10%) percent of the Contract Price. Once the maximum is reached, the Purchaser may consider termination of the Contract.

20. Termination for Default

20.1 The Purchaser may, without prejudice to any other remedy for breach of Contract, by written notice of default sent to the Supplier, terminate the Contract in whole or in part:

- a) if the Supplier fails to deliver any or all of the goods within the time period(s) specified in the Contract, or any extension thereof granted by the Purchaser; or
- b) if the Supplier fails to perform any other obligation(s) under the Contract; or
- c) if the Purchaser is of opinion that the goods does not conform to the specification and/or drawings

20.2 In the event the Purchaser terminates the Contract in whole or in part, the Purchaser may procure, upon such terms and in such manner as it deems appropriate, goods or services similar to those undelivered or unacceptable, However, the Supplier shall continue performance of the Contract to the extent not terminated.

21. Force Majeure

21.1 For purposes of this Contract, "Force Majeure" means an event beyond the control of the parties to the Contract and not involving either party's fault or negligence and not foreseeable.

21.2 If, at any time during the existence of the Contract, either party is unable to perform in whole or part any obligation under this Contract because of such events which include, but are not restricted to, acts of God, acts of Government in its sovereign capacity, war, revolutions, hostility, civil commotions, strikes, fires, floods, epidemics, quarantine restrictions, freight embargoes, explosions, then the date of fulfillment of Contract shall be postponed during the period when such circumstances are operative.

21.3 The party which is unable to perform its obligations under the present Contract shall, within fourteen (14) days of occurrence of the Force Majeure event, inform the other party with suitable documentary evidence. Non-availability of materials from regular sources or disruption of power supply shall not be an excuse for the Supplier for not performing its obligations under this clause.

21.4 Any waiver/extension of time in respect of the delivery/ acceptance of any installment or part of the goods shall not be deemed to be a waiver/extension of time in respect of the remaining deliveries.

21.5 If such inability to perform continues for a period of more than three (3) months, each party shall have the right to be released

- from further performance of the Contract, in which case, neither party shall have the right to claim damages from the other. All prior performance shall be subject to Contract terms.
- 21.6 If a Force Majeure situation arises, the Supplier shall promptly notify the Purchaser in writing of such condition and the cause thereof. Unless otherwise directed by the Purchaser in writing, the Supplier shall continue to perform its obligations under the Contract as far as is reasonably practical and shall seek all reasonable alternative means for performance not prevented by the Force Majeure event.
- 22. Termination for Insolvency** The Purchaser may at any time terminate the Contract by giving written notice to the Supplier, without compensation to the Supplier, if the Supplier becomes bankrupt or otherwise insolvent, provided that such termination will not prejudice or affect any right of action or remedy which has accrued or will accrue thereafter to the Purchaser.
- 23. Termination for Convenience** 23.1 The Purchaser, by written notice sent to the Supplier, may terminate the Contract, in whole or in part, at any time convenient to it. The notice of termination shall specify that termination is for the Purchaser's convenience, the extent to which performance of the Supplier under the Contract is terminated, and the date upon which such termination becomes effective.
- 23.2 The Goods that are complete and ready for delivery within 15 days after the Supplier's receipt of notice of termination shall be accepted by the Purchaser at the Contract terms and prices. For the remaining Goods, the Purchaser may elect:
- a) to have any portion completed and delivered at the Contract terms and prices; and/or
 - b) to cancel the remainder and pay to the Supplier an agreed amount for partially completed Goods and Services and for materials and parts previously procured by the Suppliers.
- 24. Resolution of Disputes** 24.1 The Purchaser and the Supplier shall make every effort to resolve amicably by direct informal negotiation any disagreement or dispute arising between them under or in connection with the Contract.
- 24.2 If, after twenty-eight (28) days from the commencement of such informal negotiations, the Purchaser and the Supplier have been unable to resolve amicably a Contract dispute, either party may require that the dispute be referred for resolution to the formal mechanisms. These mechanisms may include, but are not restricted to, conciliation mediated by a third party, adjudication in an agreed national or international forum, and/or national and international arbitration.
- 25. Governing Language** The Contract shall be written in the English language. The English version of the Contract shall govern its interpretation. All correspondence and other documents pertaining to the Contract which are exchanged by the parties may be written in Nepali and/or English language.
- 26. Applicable Law** The Contract shall be interpreted in accordance with the laws of Nepal.
- 27. Notices** 27.1 Any notice given by one party to the other pursuant to the Contract shall be sent to the other party in writing and confirmed in writing to the other party's address. Notice sent by facsimile or by email does not need confirmation of the receiver.

27.2 A notice shall be effective when delivered or on the notice's effective date, whichever is later.

28. Taxes and Duties

The Supplier shall be entirely responsible for all taxes, duties, license fees, etc., incurred until delivery of the contracted Goods to the final destination point.

29. Corruption

The Suppliers shall adhere to the highest ethical standards, both during the bidding process and throughout the execution of a contract. A "corrupt practice" refers to the offering, giving, receiving or soliciting (directly or indirectly) of anything of value to improperly influence the actions of another person. Corruption in the procurement process generally involves a fraudulent act such as bribery or a kickback. Contractually supplier shall declare that they are not engaged in corrupt practices; they must disclose any situation that may appear to be a conflict of interest. Helvetas Nepal has a "zero tolerance" policy regarding acceptance of gifts or hospitality; and there are restrictions on employment of former Helvetas Nepal staff members.

30. Blacklist

The purchaser cannot continue the contract with the firm/company as and when blacklisted by the Government of Nepal to the limitation of blacklisting decision.

9. SPECIAL CONDITIONS OF CONTRACT (SCC)

This SCC is a integral part of the Agreement

Clause	Item
GCC 1.1 (e)	The Purchaser is: <u>Integrated Water Resources Management Programme Helvetas Nepal, Surkhet.</u>
ITB 22	The Currency of the performance security shall be in Nepalese Rupees. The amount of the performance security shall be as follows: The successful bidder should submit a performance guarantee, issued by "A" class commercial bank specified by Nepal Rastra Bank in favour of Water Resources Management Programme (WARM-P), Helvetas Nepal with a validity of 120 days from date of award notification. The amount of performance security should be minimum of 10% of contractual amount.
GCC 11	The warranty period shall be months/year [N/A]
GCC 12	The terms of payment to be made to the Supplier under the contract shall be as follows: 1. The payment shall be made: (a) through a/c payee cheque from account division/unit of the Purchaser after successful completion of the contract.
GCC 14.4	Additional order: the purchaser can place order for additional quantity within price validity period under this agreement if required. The delivery date for additional quantity will be fixed on mutual understanding between both parties for additional order.
GCC	For notices, the Purchaser's address shall be: The Team Leader Integrated Water Resources Management Programme, Helvetas Nepal Email: water.np@helvetas.org G.P.O. Box - 688, Kathmandu, Nepal, Tel: 977-01-5524926/5522013 OR Surkhet office Itram-7, Birendranagar, Surkhet Ph: 083-521092/093 For notices, the Supplier's address shall be: Name and Address of the Supplier: Telephone number: Facsimile number: e-mail Address:

10. SAMPLE FORMS AND FORMATS

10.1 CONTRACT AGREEMENT

THIS AGREEMENT made on the day of between Integrated Water Resources Management Programme, Helvetas Nepal, Birendranagar, Surkhet (hereinafter "the Purchaser"), of the one part, and M/s of Nepal (hereinafter "the Supplier"), of the other part:

WHEREAS the Purchaser invited Bids for certain Goods and Related Services, viz **supply and delivery of various construction materials for drinking water and sanitation schemes** and has accepted a Bid by the Supplier for the supply of those Goods and Related Services in the sum of NRs. [in words] (hereinafter "the Contract Price").

NOW THIS AGREEMENT WITNESSETH AS FOLLOWS:

1. In this Agreement, words and expressions shall have the same meanings as are respectively assigned to them in the Contract referred to.
2. The following documents shall be deemed to form and be read and construed as part of this Agreement, viz.:
 - (a) the Letter of Acceptance;
 - (b) the Bid Submission Sheet and the Price Schedules submitted by the Supplier;
 - (c) the Special Conditions of Contract;
 - (d) the General Conditions of Contract;
 - (e) the Schedule of Supply; and
 - (f) any other documents shall be added here.

This Contract shall prevail over all other Contract documents. In the event of any discrepancy or inconsistency within the Contract documents, then the documents shall prevail in the order listed above.

3. In consideration of the payments to be made by the Purchaser to the Supplier as indicated in this Agreement, the Supplier hereby covenants with the Purchaser to provide the Goods and Related Services and to remedy defects therein in conformity in all respects with the provisions of the Contract.
4. The Purchaser hereby covenants to pay the Supplier in consideration of the provision of the Goods and Related Services and the remedying of defects therein, the Contract Price or such other sum as may become payable under the provisions of the Contract at the times and in the manner prescribed by the Contract.
5. The suppliers should be issue VAT invoice in the name of **Integrated Water Resources Management Programme, Helvetas Nepal, Surkhet** and roughly corrected invoices will not be accepted.
6. The purchaser can place order for additional quantity within price validity period under this agreement if required. The delivery date for additional quantity will be fixed on mutual understanding between both parties for additional order.

IN WITNESS whereof the parties hereto have caused this Agreement to be executed in accordance with the laws of Nepal on the day, month, and year indicated above.

On behalf of

Integrated Water Resources Management Programme,
Helvetas Nepal

Signature:

Name:

Designation:

Date:

Seal:

Witness,

Signature:

Name:

On behalf of the Supplier

Signature:

Name:

Designation:

Date:

Seal:

Signature:

Name:

10.2 PERFORMANCE SECURITY

[insert Bank's Name, and Address of Issuing Branch or Office]

Date: [insert date]

Beneficiary: **Water Resources Management Programme
(WARM-P)/Helvetas Nepal**
Surkhet

Date:

Performance Guarantee No.:

We have been informed that name of the supplier.
(hereinafter called "the Supplier") has entered into Contract No. reference
number of the contract. dated with you, for the
execution of name of contract and brief description of
goods and related services. (hereinafter called "the Contract").

Furthermore, we understand that, according to the conditions of the Contract, a performance
guarantee is required.

At the request of the Supplier, we name of the
bank. hereby irrevocably undertake to pay you any
sum or sums not exceeding in total an amount of name of the
currency and amount in words (.
. amount in figures.) such sum
being payable in the types and proportions of currencies in which the Contract Price is
payable, upon receipt by us of your first demand in writing accompanied by a written statement
stating that the Supplier is in breach of its obligation(s) under the Contract, without your
needing to prove or to show grounds for your demand or the sum specified therein.

This guarantee shall expire, no later than the day of
., and any demand for payment under it must be received by us at this office on or before
that date.

.....
Signature(s) and seal of bank (where appropriate)



10.3 BID SECURITY

[insert Bank's Name, and Address of Issuing Branch or Office]

Date: [insert date]

Beneficiary Name: Water Resources Management Programme (WARM-P),
Helvetas Nepal, Surkhet

BID GUARANTEE No.: [insert guarantee number]

We have been informed that [insert name of the bidder] (hereinafter called "the bidder") intends to submit its bid to you (hereinafter called "the Bid") for the execution of [insert name of procurement contract] under Invitation for Bids No. [insert contract number] ("the Invitation").

Furthermore, we understand that, according to your conditions of contract, bids must be supported by a bid guarantee.

We [insert name of issuing Bank] hereby irrevocably undertake to pay you a total amount of [insert amount in figures of bid security] [insert amount in words] upon receipt by us of your first demand in writing accompanied by a written statement stating that the bidder is in breach of its obligation under the bid conditions.

This guarantee will expire in days after the expiration of the bidder's bid which comes to be [insert the date of expiry of the bid security].

Consequently, any demand for payment under this guarantee shall be received by us at the office on or before expiry date of bid security.

Name _____
In the capacity of _____
Signed _____

Duly authorized to sign the Bid Security for and on behalf of _____
Date _____

10.4 LETTER OF ACCEPTANCE

[on letterhead paper of the Purchaser]

Date.....

To: Name and address of the Supplier

Subject: Notification of Award

This is to notify that your sealed bid related to bid notice dated for supply and delivery of Package for the Contract price of Nepalese Rupees (in words: only) has been accepted by us in accordance with the Instruction to bidders.

You are hereby informed to contact this office for formal contract agreement latest by before 5:00 PM accompanying an unconditional performance security of NRs. (in words: only) from a "A" class commercial bank specified by Nepal Rastra Bank in favour of **Water Resources Management Programme (WARM-P), Helvetas Nepal, Surkhet**. The validity of performance security must be **120 days**. As per the Conditions of Contract, you are also required to submit performance guarantee, as specified in the format included in the Bidding Document.

In case you fail to furnish the performance security and to sign the contract within specified period, the purchaser reserves the right to cancel this award notification.

Authorized Signature:

Name and Title of Signatory:



11. ANNEX-I

Code of Conduct for Contracted Parties

1. Scope of this Code of Conduct

HELVETAS Swiss Intercooperation (hereinafter HELVETAS) is a civil society organisation for development and humanitarian response. We strive to empower people, so they can determine the course of their lives in dignity and security, using environmental resources in a sustainable manner. Our work is guided by the following values¹:

- Our engagement is based on solidarity and partnership.
- We work towards achieving human rights and upholding the principle of self-determined development.
- We are committed to social equity and strive for equal opportunities for men and women regardless of age, origin, language, religion, culture, mental and physical capacity, sexual orientation, or political convictions.
- Our collaboration with our partners is based on mutual respect for cultural values and principles
- We stand for development that balances economic viability, environmental appropriateness and social benefits.

The organisational values are the basis for the attitude, behaviour and high standards that HELVETAS requests to be respected and adhered to by its employees.

Further, we expect that all individuals and institutions with whom HELVETAS engages, respect these values and act in accordance with them, as well as with national and international laws. This applies both to professional contexts and to private matters that have an influence on the professional domain.

This Code of Conduct outlines the attitude and the behaviour that HELVETAS expects from consultants, services providers of goods and services, implementation partners, system partners and assisted organisations – in the following called **contracted parties** – that are responsible for implementing projects, project components and/or recipients of contributions, etc. in Switzerland as well as abroad.

This Code of Conduct is binding, and an integral part of all contractual agreements made between HELVETAS and its contracted parties. In signing their contract, contracted parties take on the commitment to observe the Code of Conduct, to ensure adherence by their personnel and their subcontractors, and to behave accordingly. Any action violating the Code of Conduct may entail an enquiry and the imposition of measures relating to non-compliance with contractual obligations, or of other measures.

Contracted parties are expected to ensure that their employees and any person working for them adhere to this Code of Conduct by putting in place adequate policies and regulations and through sensitisation, supervision and training of concerned persons.

¹ Organisational Strategy HELVETAS Swiss intercooperation

2. The Components of the Code of Conduct

Loyalty and confidentiality and civic duty	The actions of contracted parties in the frame of the collaboration with HELVETAS must be consistent with the goals, the values and principles of HELVETAS as expressed in its mission statement and organisational strategy. Contracted parties are expected to regularly reflect upon own actions and behaviour and those of subcontractors. Contracted parties, their employees and subcontractors commit to abide by the national laws, as citizen or resident of a specific country or as a short-term visitor.
Use of competences, means and assets	Contracted parties, their employees and subcontractors contribute with their competences and capacities to the objectives of the collaboration. They commit to make use of available means and assets effectively and efficiently, according to legal stipulations, internal regulations, contractual agreements and in conformity with project goals.
Culturally sensitive behaviour	Contracted parties, their employees and subcontractors are aware that even as private persons, they are subject to public interest. They must consider this in behaviour and statements. Contracted parties, their employees and subcontractors must respect local norms and conventions in contacts with authorities, partners and local people. They must respect the customs and culture of the country of cooperation in appearance and manner of dress, behaviour and communication. They must respect the customs and culture of the country, avoiding indecent or offensive behaviour, insulting or accusing statements, or spreading rumours.
Inter-personal relations and professional conduct	Contracted parties, their employees and subcontractors must have respectful, fair and equitable relations with all persons irrespective of their age, origin, language, religion, culture, social position, physical ability or sexual orientation. They are aware of their privileged and often powerful status vis-à-vis other actors and must refrain from abusing any hierarchical, material, or social position in any way. They never request any service or favour from primary stakeholders or other persons of concern in return for support or protection. They never engage in any exploitative relationships – sexual, emotional, financial or employment-related – with primary stakeholders or other persons of concern. They must refrain from any form of disrespectful social interaction and abstain from anything that could be interpreted as degrading or putting others down.
Protection of children and youth	Contracted parties, their employees and subcontractors commit to protect the rights and integrity of children and youth and must refrain from all forms of abuse towards them in accordance with the universal Convention on the Rights of the Child. ²
Mobbing and sexual harassment	Contracted parties, their employees and subcontractors abstain from mobbing ³ , sexual or sexist harassment ⁴ of colleagues, partners or any other person.

² <https://www.ohchr.org/en/professionalinterest/pages/crc.aspx>

³ **Mobbing** means to pick on, pester or exclude a person or a group systematically at work in verbal or non-verbal attacks which affect the physical or mental health as well as the self-esteem of the person(s) concerned

⁴ **Sexual or sexist harassment** is an action with sexual reference or undertones unwelcome to the person addressed. Sexual or sexist harassment can be expressed in the following ways: suggestive remarks; remarks about physical advantages or weaknesses or about sexual orientation; sexist talk and jokes in any form of verbal, written or non-verbal communication;

Conflict of Interest and duty of disclosure	Contracted parties, their employees and subcontractors are aware that professional interests can conflict with organisational or personal interests. Therefore, they must make own interests transparent and avoid any behaviour which could be perceived as biased in favour own interests.
Fraud and corruption and accepting gifts or other benefits	Contracted parties, their employees and subcontractors are must be honest in all professional activities, avoiding and countering any kind of corruption. They abstain from abusing financial, material and intellectual assets to which they have access in relation with the HELVETAS mandate for personal gains or for third parties. They do not accept gifts, invitations or other favours that may afford them or third parties an unfair material or immaterial advantage, or that may compromise their integrity, freedom of action, or impartial judgement. Contracted parties must inform HELVETAS if confronted with corrupt practices or unethical promises by collaborators, partners organization, consultants, officials or others. The applicable reporting mechanisms are specified in chapter 3 of this Code of Conduct.
Safety, Security & Health	Contracted parties undertake to safeguard the personal safety, health and integrity of their employees and refrain from putting others in a dangerous situation. Contracted parties, their employees and subcontractors must respect the physical and mental integrity of their colleagues and others.
Environmental and Social Safeguarding	Contracted parties, their employees and subcontractors are expected to wherever possible support a precautionary approach to environmental matters and undertake efforts to safeguard natural resources. Contracted parties must promote good governance principles, namely participation, inclusion, integrity, effectiveness, transparency, rule of law, and accountability. Contracted parties, their employees and subcontractors must ensure that their professional actions and their motivations are understood and transparent.
Public appearances and use of non-public information	Contracted parties handle all information received in relation with the contract with the necessary discretion, never using it to the detriment of HELVETAS or beneficiaries including after termination of the contract. Persons working for contracted parties should not provide aforesaid information to the media, policy makers and donors or the public, without an explicit assignment to do so. In public communication they must provide explicit reference to the sources of the information/experiences. They must refrain from making accusations, provocative statements or spreading rumours. They give due consideration to their cooperation with HELVETAS and to its interests in their communications, particularly via the internet or social media

3. Reporting mechanism of a violation of the Code of Conduct and Whistleblowing

Any person working for a contracted party of HELVETAS who feels under pressure to act in a way that runs counter to this Code of Conduct, or who witnesses violations of the same, must inform either the management of the contracted party and/or HELVETAS. The contracted party is obliged to share the reported cases and action taken with HELVETAS.

sharing suggestive material over email or social media; ambiguous invitations; making bodily advances; making advances together with promises or threats of advantages or disadvantages at work.

The whistleblowing policy (e.g. whistle-blower protection) of HELVETAS applies to all employees worldwide and to persons working for contracted parties. All concerns will be treated confidentially, and every effort will be made not to reveal the identity of the whistle-blower. The policy is publicly available on HELVETAS' website and the specified contacts are accessible for anyone.

4. Consequences of a violation of this Code of Conduct

In case of breach of this Code of Conduct by contracted parties, their employees and subcontractors, HELVETAS expects them to sanction misbehaving persons similar to HELVETAS' measures. These sanctions range from requesting apologies, written warnings to dismissal of guilty persons. In serious cases or if no appropriate sanctions are taken, HELVETAS reserves the right to end the collaboration, ask for compensation of financial losses or to pursue legal action.

5. Final Remarks

HELVETAS encourages its contracted parties to create their institutional codes of conducts and related policies and regulations, including internal reporting procedures that enable their employees and subcontractors, as well as third parties, to promote professional, respectful, inclusive and secure working conditions; and safely report instances of wrongdoing to the management or to an independent body.

HELVETAS is committed to mutual transparency and learning on any aspect of this Code of Conduct. HELVETAS is therefore available for consultation in cases of doubt or questions relating to the Code of Conduct.

This Code of Conduct is issued in French, English and Spanish. In case of any doubts, the English version prevails.

Read and agreed

Name of the contracted party:

Name of signatory of contracted party:.....

Place and date

Signature:



12. ANNEX-II: SCHEME WISE MATERIAL SUMMARY

S. No.	Materials Name	Unit	Required quantity				Total Quantity
			Gogane DWS, Chingad-1, Surkhet	Saunepani Awaldhuwani DWS, Chingad-3, Surkhet	Siyala Khola DWS, Chingad-4, Surkhet	Thatibazar DWS, Chingad-3, Surkhet	
	Fabrication Items						-
1	Angle Pole	No	35.00	22.00	21.00	17.00	95
2	Angle Pole for Gate	No	20.00	12.00	6.00	6.00	44
3	Angle Pole for Corner	No	40.00	24.00	12.00	12.00	88
4	Angle Pole for Bracing	No	64.00	44.00	20.00	20.00	148
5	Angle Gate	No	10.00	6.00	3.00	3.00	22
6	Square Slab Frame (Small)	No	4.00	4.00	1.00	2.00	11
7	Square Slab Frame (Big)	No	14.00	18.00	10.00	5.00	47
8	Square Slab Frame (Big) with Metal Cover	No	4.00	3.00	1.00	2.00	10
9	Iron Bracket 1/2"	Pc	3.00	2.00	-	-	5
10	Iron Bracket 1-1/4"	Pc	-	1.00	-	-	1
11	Iron Bracket 2-1/2"	Pc	1.00	-	-	-	1
12	Tool box (empty)	Pc	1.00	1.00	1.00	1.00	4
13	Slab frame key	Pc	8.00	4.00	4.00	4.00	20
14	Tapstand Grid	No	5.00	-	-	4.00	9
15	Information Board	Set	1.00	1.00	1.00	1.00	4