



**BIDDING DOCUMENT**

**FOR**

**THE PROCUREMENT**

**OF**

**PACKAGE-I : supply and delivery of various construction materials for drinking water supply and sanitation Scheme in Lekhbeshi, Surkhet**

**IFB (invitation for bid) No.: IWRM/11/2022**

**Issued by**

---

**Integrated Water Resources Management Programme  
Helvetas Nepal**

**Birendranagar, Surkhet**

**Date of issue: 27 December 2022**

A handwritten signature in black ink, appearing to be "A. B. R.", located to the left of the Helvetas Nepal logo.



## Abbreviations

BDS.....	Bid Data Sheet
BD .....	Bidding Document
EQC .....	Evaluation and Qualification Criteria
GCC .....	General Conditions of Contract
IFB .....	Invitation for Bids
ITB .....	Instructions to Bidders
SBD.....	Standard Bidding Document
SCC .....	Special Conditions of Contract
SoR .....	Schedule of Requirements
TS .....	Technical Specifications
VAT .....	Value Added Tax

*Handwritten signature*





## Table of Contents

	Page No.
1. INVITATION FOR BID (IFB)	2
2. INSTRUCTIONS TO BIDDERS (ITB)	3
3. BID DATA SHEET (BDS)	7
4. EVALUATION AND QUALIFICATION CRITERIA (EQC)	8
5. BID FORM AND PRICE SCHEDULE	9
6. SCHEDULE OF REQUIRMENTS (SOR)	27
7. SPECIFICATIONS & QUALITY ASSURANCE	28
8. GENERAL CONDITIONS OF CONTRACT (GCC)	45
9. SPECIAL CONDITIONS OF CONTRACT (SCC)	51
10. SAMPLE FORMS AND FORMATS	52
11. ANNEX-I	56



## 1. INVITATION FOR BID (IFB)



### INVITATION FOR BIDS

Date of first publication: 27 December 2022

1. Integrated Water Resources Management Programme, Helvetas Nepal, Birendranagar, Surkhet invites sealed Bid from the interested and competent suppliers/vendors for the **supply and delivery of various construction materials for drinking water supply and sanitation scheme as per following packages:**
  - Package-I Various construction materials (HDPE Pipe, fabricated materials, rebar, plain wire, barbed wire, chicken wire mesh, GI Pipe fitting, Valves, and tools, etc.) for Lekbeshi, Surkhet
  - Package-II Fabricated materials (Iron works) for Berekot, Jajarkot
  - Package-III Various construction materials (HDPE Pipe, rebar, plain wire, barbed wire, chicken wire mesh, GI Pipe fitting, Valves, and tools, etc.) for Berekot, Jajarkot
2. The eligible bidders may obtain further information about the requirements and clarity on the bid document at office address, phone number or email mentioned below. We will response to such a query during office hours (9AM to 5PM).
3. The bidders can download bidding documents from the Helvetas Nepal's website: [www.helvetas.org/en/nepal/who-we-are/follow-us/public-announcements](http://www.helvetas.org/en/nepal/who-we-are/follow-us/public-announcements)
4. **Date of pre-bid meeting (online):** 02 January 2023 at 2PM. Interested potential bidders can contact to [water.np@helvetas.org](mailto:water.np@helvetas.org) on or before 12:30PM by 02 January 2023 to participate the meeting.
5. **Sealed bids must be submitted to the office address as follows:**  
**Helvetas Nepal, Birendranagar-7, Itram, Surkhet**
6. The last date for submission of sealed bid is on **09 January 2023 latest by 12PM.**
7. The bids will be opened on **09 January 2023, at 1PM** in the presence of Bidder's representatives who choose to attend.
8. Bid security should be in a form of bank guarantee issued by "A" class commercial bank in favour of "**Water Resources Management Programme (WARM-P) Helvetas Nepal**", which is convertible into cash in Nepal without any condition (unconditional). The bid security amount is as follows:
  - a) Package-I : NRs 250,000 (in words: two hundred fifty thousand only)
  - b) Package-II : NRs. 25,000 (in words: twenty-five thousand only)
  - c) Package-III : NRs. 150,000 (in words: one hundred fifty thousand only)
9. The purchaser reserves the right to accept or reject any bid partially or fully without assigning any reasons whatsoever.

#### Helvetas Nepal

Birendranagar-7, Itram, Surkhet  
Phone no: 083-521092, 083-521093  
Email: [water.np@helvetas.org](mailto:water.np@helvetas.org)

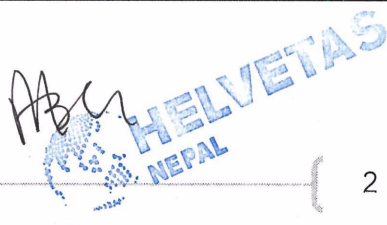

## 2. INSTRUCTIONS TO BIDDERS (ITB)

<b>1. Scope of Works</b>	1.1 The Purchaser stated in the Bid Data Sheet (BDS) for the procurement of Goods as detailed in attached specifications, drawings and the bill of quantities provided herein. The name of Purchaser, name of project and contract identification number of Contracts are provided in the Bid Data Sheet (BDS).
<b>2. Eligible bidder</b>	2.1 This Invitation for Bid is open to all registered local manufactures/suppliers. 2.2 Eligible and competent bidder must submit the following documents along with the bid. - documents as specified in EQC (4.1)
<b>3. One bid per bidder</b>	3.1 Each bidder shall submit only one bid, A bidder who submits more than one bids shall cause all the bids with the bidder's participation to be disqualified.
<b>4. Site Visit</b>	4.1 The bidder at his own cost, responsibility and risk may visit the site of the supply, delivery or installation of Goods and acquire all necessary information for preparing the bid and entering into a contract for the procurement of Goods.
<b>5. Content of Bid</b>	5.1 The bid document comprise the documents listed below: Section I: Invitation for Bids (IFB) Section II: Instructions to Bidders (ITB) Section III: Bid Data Sheet (BDS) Section IV: Evaluation and qualification criteria (EQC) Section V: Bid Forms and Price Schedule Section VI: Schedule of Requirements (SOR) Section VII: Specification and quality assurance. Section VIII: General Conditions of Contract (GCC) Section IX: Special Conditions of Contract Section X: Contract Form and formats Section XI: Annex
<b>6. Clarification</b>	6.1 A Prospective bidder may request clarification on the bidding documents in writing and the purchaser shall respond to such request. Clarification will be provided by purchaser 3 days before the last date of bid submission. 6.2 The purchaser may organize a pre-bid meeting of bidders before bid opening at the place, date and time as specified in the BDS to provide information relating to Bidding Documents and technical specifications. Interested bidder should obtain the bid document before pre-bid meeting.
<b>7. Amendment of Bidding Document</b>	7.1 At any time prior to the deadline for submission of the Bids, the Purchaser may amend the Bid Document by issuing addenda. 7.2 Any addendum issued shall be part of the Bidding Document and shall be communicated in writing to all who have obtained the Bidding Document directly from the Purchaser. Such Addendum notice shall also be published in the online/National newspaper.
<b>8. Cost of bidding:</b>	8.1 The Bidder shall bear all costs associated with the preparation and submission of its Bid, and the Purchaser shall not be responsible or liable for those costs, regardless of the conduct or outcome of the bidding process.
<b>9. Language of Bids:</b>	9.1 All correspondence and documents relating to the Bids shall be written in English or in Nepali language.



STANDARED BID DOCUMENT

<b>10. Alternative Bids</b>	10.1 Alternative bids shall not be considered.
<b>11. Bidding price:</b>	<p>11.1 All duties, taxes/transportation/loading/offloading/insurance, and other levies payable by the bidder under the contract shall be included in the rates, prices and total Bid Price submitted by the bidder.</p> <p>11.2 Price quoted by the bidder shall remain fixed and valid until completion of the Contract Performance and will not be subject to variation in any account.</p> <p>11.3 Bids and quoted rates shall remain valid for the period specified in the Bid Data Sheet. A bid valid for a shorter period shall be rejected by the purchaser as nonresponsive.</p> <p>11.4 If the purchaser determines the quoted rates of Bill of Quantity items by supplier are deviated unevenly leads to rejection of such bids as a nonresponsive.</p>
<b>12. Unbalanced or Front/back-loaded bid</b>	<p>12.1 If the purchaser found the item rates of the substantially lowest evaluated bid is seriously unbalanced or front-loaded or backloaded; may require the bidder to produce detailed price analysis for all items listed in price schedule of the bid document to demonstrate the price consistency of those rates with the authorized sources of the same.</p> <p>12.2 After the verification and assurance of the information and details of price analysis presented by the bidder, purchaser may accept or reject the bid.</p>
<b>13. Currencies of Bid</b>	13.1 All prices shall be quoted in Nepalese Rupees.
<b>14. Bid validity</b>	14.1 1. Bid shall remain valid for a period specified in the BDS.
<b>15. Bid Security</b>	<p>15.1 The bidder shall furnish as part of the bid, in original form, a bid security as specified in BDS.</p> <p>15.2 Bid security should be in a form of bank guarantee issued by "A" class commercial bank in favour of purchaser, which is convertible into cash in Nepal without any condition (unconditional) as specified in BDS.</p> <p>15.3 The bid security shall be returned upon request to unsuccessful bidder as soon as possible after formal contract signing.</p> <p>15.4 The Bid security shall be forfeited if the successful Bidder fails to:</p> <ul style="list-style-type: none"> <li>- furnish a performance security,</li> <li>- sign the contract in accordance within the period stipulated in letter of award notification,</li> <li>- accept the correction of arithmetical errors,</li> <li>- provide the clarification of its bid by the date and time set in the purchaser's request for clarification.</li> </ul>
<b>16. Preparation of bid and submission</b>	<p>16.1 The compiled and completed bid shall be sign and put bidder's stamp on every pages.</p> <p>16.2 The sealed envelope as per ITB 16.1 must reach within the deadline to purchaser's address specified in the BDS complying method of submission in the BDS. The envelope shall be addressed to the Purchaser as specified in the BDS and shall bear the name and identification number of the sealed bid.</p> <p>16.3 Unit rate in figures and words are not mentioned clearly in BOQ, it may lead to rejection and disqualification of the bid.</p>
<b>17. Deadline for Submission of Bids:</b>	<p>17.1 Bidding documents shall be sent to the Purchaser at the address no later than the time and date specified in the Bid Data Sheet (BDS).</p> <p>17.2 The Purchaser shall not consider any Bid that arrives after the deadline for submission of Bids. Any Bid received by the</p>

**STANDARED BID DOCUMENT**

	<p>Purchaser after the deadline for submission of Bids shall be declared late, rejected, and returned unopened to the bidder.</p> <p>17.3 Bidding document once submitted shall not be withdrawn or modified.</p> <p>17.4 If the last date of purchasing, submission, and opening falls on a Helvetas Nepal holiday then the next working day shall be considered the last day.</p>
<b>18. Bid Opening:</b>	<p>18.1 The Purchaser shall open the bids in the presence of the bidders' representatives who choose to attend at the time and in the place as specified in the Bid Data Sheet (BDS).</p> <p>18.2 The Purchaser shall prepare minutes of the opening including the information disclosed to those present.</p>
<b>19. Process to be Confidential:</b>	<p>19.1 Information relating to the evaluation and comparison of Bids and recommendations for the award of a contract shall not be disclosed to bidders or any other persons not officially concerned with such process until the award to the successful bidder has been announced.</p> <p>19.2 Any efforts by the bidder to influence the Purchaser in the Bid evaluation, comparison or contract award decisions may result in rejection of bidder's Bids.</p>
<b>20. Evaluation criteria:</b>	<p>20.1 The purchaser shall evaluate the bid in accordance with set criteria as specified in the evaluation and qualification criteria (EQC).</p>
<b>21. Evaluation and Comparison of bids:</b>	<p>21.1 In evaluating the bids, the Purchaser shall determine for each bid the evaluated bid price by adjusting any corrections for errors. Bids shall be checked by the Purchaser for any arithmetic errors. Errors shall be corrected by the Purchaser as follows:</p> <p>21.2 If there is a discrepancy between the unit price and the total price that is obtained by multiplying the unit price and quantity, the unit price shall prevail, and the total price shall be corrected.</p> <p>21.3 If there is an error in a total corresponding to the addition or subtraction of subtotals, the subtotals shall prevail, and the total shall be corrected.</p> <p>21.4 If there is a discrepancy between words and figures, the amount in words shall prevail, unless the amount expressed in words is related to an arithmetic error, in which case the amount in figures shall prevail.</p> <p>21.5 If the purchaser determines the quoted rates of BoQ items by supplier are deviated unevenly leads to rejection of such bids.</p> <p>21.6 While quoting rates, the bidder shall not be allowed to use correcting fluid or other erasing materials; neither the bidder shall be allowed to overwrite the quoted rates. It may result to rejection of the bid document. In case of mistakes in rates, the bidder is to simply cross the rates and shall re-write the rates and shall bear the initials of authorized signatories and company/firm's stamp.</p>
<b>22. Notification of Award and contract signing</b>	<p>22.1 The purchaser shall award the contract to the bid as per bid data sheet.</p> <p>22.2 The successful bidder shall deliver the performance security as specified in SCC.</p> <p>22.3 If the successful bidder fails to deliver the Performance Security and sign the contract within specified time, the purchaser holds right to award the contract to next lowest evaluated substantially responsive bid or decide as per purchaser's convenience.</p>

ABH





**STANDARED BID DOCUMENT**

<p><b>23. Performance Security</b></p>	<p>23.1 Within deadline of the receipt of Letter of Acceptance from the purchaser, the successful bidder shall furnish the performance security in a form of Bank Guarantee from "A" class commercial bank acceptable to the purchaser.</p> <p>23.2 The proceeds of the performance security shall be payable to the purchaser as compensation for any loss resulting from the supplier's failure to complete its obligations under the Contract.</p> <p>23.3 The amount of performance security will be according to BDS.</p>
<p><b>24. Goods Delivery:</b></p>	<p>24.1 The bidders should make delivery of ordered quantities in place and time as per clause 6.1 of the bid document under Schedule of Requirement (SoR).</p> <p>24.2 All the delivered materials must comply the quality and specification mentioned in the specification section of this bid document. The supplier must ensure the proper packing and safeguarding from damage of goods during supply.</p>
<p><b>25. Payment:</b></p>	<p>25.1 Payment will be made upon receiving materials along with the valid tax invoice and successful delivery evidence.</p> <p>25.2 Payment can be made full or partial as per convenience of purchaser.</p>
<p><b>26. Format and signing of bids:</b></p>	<p>26.1 The Bid shall be typed or written in indelible ink and shall be signed by an authorized person. Any entries or amendments including alternations, additions or corrections made shall be initialed by the same authorized person.</p>
<p><b>27. Joint Venture</b></p>	<p>27.1 Joint venture (JV) bids shall not be considered.</p>
<p><b>28. Purchaser's Right to Accept or Reject</b></p>	<p>28.1 The Purchaser reserves the right to accept or reject any Bid or to cancel the bidding process and reject all Bids, at any time prior to the award of the contract, without assigning any reasons whatsoever and without thereby incurring any liability to the affected bidder or bidders.</p>
<p><b>29. Confusing Specification</b></p>	<p>29.1 If the parameters of the specification are confused, manufacturer's certificate (origin of certificate) will prevail.</p>
<p><b>30. National product</b></p>	<p>30.1 We encourage/promote national products if equally qualified with the international product.</p>
<p><b>31. Corrupt of Fraudulent practices</b></p>	<p>31.1 The purchaser shall reject the bid for award if it determines that the Bidder recommended for award of contract has engaged in corrupt or fraudulent practices in competing for the contract in question.</p>

### 3. BID DATA SHEET (BDS)

ITB 1	<p>The scope of bid is to supply and delivery of Package-I Various construction materials (HDPE Pipe, fabricated materials, rebar, plain wire, barbed wire, chicken wire mesh, GI Pipe fitting, Valves, and tools, etc.) for Lekbeshi, Surkhet.</p> <p>The number of the Invitation for Sealed bid is: <b>IWRM/11/2022</b></p> <p>The Purchaser: <b>Integrated Water Resources Management Programme Helvetas Nepal, Surkhet.</b></p>
ITB 6	<p>The pre-bid meeting shall be conducted in the following:</p> <p>Date : <b>02 Jan 2023</b></p> <p>Time : <b>02:00PM</b></p> <p>Place : <b>Online-Microsoft team</b></p>
ITB 14	<p>Bids and quoted rate shall be valid at least <b>45 days</b> from the date of bid submission.</p> <p><i>It can be extended for further period if both parties are agreed.</i></p>
ITB 15	<p>Beneficiary name for bid security: <b>Water Resources Management Programme (WARM-P), Helvetas Nepal, Surkhet</b></p> <p>The bid must be accompanied by bid security, amounting to a minimum of <b>NRs 2,50,000.00</b> (Two hundred fifty thousand only), the validity of bid security for <b>45 days from 09 January 2023.</b></p>
ITB 17	<p><b>The deadline for sealed bid submission is:</b></p> <p>Address: <b>Helvetas Nepal, Itram, Birendranagar, Surkhet</b></p> <p>Date: <b>09 January 2023</b></p> <p>Time: <b>Before 12: 00 PM</b></p> <hr/> <p><b>Method of bid submission:</b> The bidder must submit the sealed bid in the following method:</p> <p>Method: <b>Hard copy submission (only sealed hard copy envelope is accepted)</b></p>
ITB 18	<p>The bid opening schedule:</p> <p>Address: <b>Helvetas Nepal, Itram, Birendranagar, Surkhet</b></p> <p>Date: <b>09 January 2023</b></p> <p>Time: <b>1:00 PM</b></p> <p>The Purchaser shall open the bids at scheduled date, time and place. Bidders or their representatives are encouraged to participate in the bid opening event.</p>
ITB 22.1	<p>The contract shall be awarded to lowest evaluated substantially responsive bid.</p>
ITB 23	<p><b>The performance security: 10%</b> of total contract price with minimum validity of <b>90 days</b> from the award notice.</p>

ABh



---

**4. EVALUATION AND QUALIFICATION CRITERIA (EQC)**

---

The required form and documents shall be part of technical bids.

SN	Particulars	Requirements
1	Copy of firm/company registration certificate	Mandatory
2	Copy of VAT registration certificates	Mandatory
3	Copy of tax clearance certificate for the fiscal year <b>2078/079</b> <b>Or 2077/2078 with time extension</b>	Mandatory
4	Original copy of bid security	Mandatory
5	Has been properly signed by the authorized person as per ITB 16.1	Mandatory
6	Completed price schedule as per ITB 16.3	Yes/No
7	Use of correction fluid/overwrite. (if yes, authorized signature and stamp is needed)	Yes/No

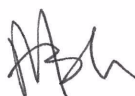



---

## 5. BID FORM AND PRICE SCHEDULE

---

### 5.1 LETTER OF BID

To: **Integrated Water Resources Management Programme  
Helvetas Nepal  
Surkhet**

We, the undersigned, declare that:

- a) We have examined and have no reservations to the Bidding Documents.
- b) We offer to execute in conformity with the Bidding Documents the following Works:
- c) **The total price of our Bid, excluding any discounts offered in item (d) below is: .....**
- d) **The discounts offered in this bid is :..... (discount offer other than in this section will not be accepted. Such a discount offer should be mentioned either percentage or in figure clearly).**
- e) Our bid shall be valid for a period of **45 days** from the date fixed for the bid submission deadline in accordance with the Bidding Documents, and it shall remain binding upon us and may be accepted at any time before the expiration of that period.
- f) If our bid is accepted, we commit to obtain a performance security in accordance with the Bidding Document.
- g) We understand that this bid, together with your written acceptance thereof included in your notification of award, shall constitute a binding contract between us, until a formal contract is prepared and executed.
- h) **We declare that we have not been blacklisted and no conflict of interest in the proposed procurement proceedings and we have not been punished for an offense relating to the concerned profession or business.**
- i) We understand that you are not bound to accept the lowest evaluated bid or any other bid that you may receive; and
- j) If awarded the contract, the person named below shall act as contractor's representative:
- k) If awarded the contract, contractor respect and comply the purchaser's code of conduct unless violating the prevailing rules of Government of Nepal.
- l) We agree to permit the Employer or its representative to inspect our accounts and records and other documents relating to the bid submission and to have them audited by auditors appointed by the purchaser.

Authorized signature: \_\_\_\_\_

Name \_\_\_\_\_

In the capacity of \_\_\_\_\_

Company Name \_\_\_\_\_

Company Seal/stamp: \_\_\_\_\_

Date: \_\_\_\_\_



## STANDARED BID DOCUMENT

### 5.2 BIDDER'S INFORMATION FORM

*[The bidder shall fill in the following Form. No alterations to its format shall be permitted and no substitutions shall be accepted.]*

1.	Bidder's Legal Name	
2	Bidder's Address:	
3	Bidder's Country of Registration:	Nepal
4.	Bidder's Year of Registration:	
5.	Bidder's Authorized Representative Information: Name: Address: Telephone/Fax numbers: Email Address:	
6	Bidder's Telephone/Fax numbers:	
7	Bidder's Email Address:	



## 5.3 PRICE SCHEDULE:

S. No.	Materials Name	Unit	Quantity	Rate in NRs. (Including transportation/loading/offloading/insurance etc. cost)		Amount	Remark
				In Figure	In Words		
1	Cement OPC 53	Bag	500				
	<b>Other Construction Materials</b>						
2	Rebar (8mm)	Kg	379.46				
3	Rebar (10mm)	Kg	533.88				
4	Binding wire	Kg	34.23				
5	Plain wire (3.5mm) Heavy	Kg	327.57				
6	Chicken wire mesh 22 g	m	369				
7	Polythene Sheet	m	94				
8	Barbed Wire	Kg	481.16				
9	Gate Lock (Tala 50mm)	Pc	20				
10	Nut with bolt (8mm dia)	Pc	200				
11	GI sheet Plain (3'x7')	Pc	5				

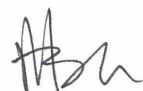

S. No.	Materials Name	Unit	Quantity	Rate in NRs. (Including transportation/loading/offloading/insurance etc. cost)		Amount	Remark
				In Figure	In Words		
12	Cement Paint (White)	Kg	52.37				
13	Machine Made Gabion Box (2x1x1)	Kg	8				
14	Nails 2"	Kg	3.93				
15	Suspension Cable (10mm)	m	172				
16	Bull Dog Grip (10mm)	Pc	8				
17	200 Litre PE Tank	Pc	2				
	<b>HDPE Pipes</b>						
18	HDPE Pipe 20mm -PN16	m	1785				
19	HDPE Pipe 25mm -PN12.5	m	4901				
20	HDPE Pipe 32mm -PN10	m	4791				
21	HDPE Pipe 32mm -PN12.5	m	628				
22	HDPE Pipe 32mm -PN16	m	425				
23	HDPE Pipe 40mm -PN10	m	6597				



S. No.	Materials Name	Unit	Quantity	Rate in NRs. (Including transportation/loading/offloading/insurance etc. cost)		Amount	Remark
				In Figure	In Words		
24	HDPE Pipe 40mm -PN12.5	m	816				
25	HDPE Pipe 40mm -PN16	m	405				
26	HDPE Pipe 50mm -PN6	m	10				
27	HDPE Pipe 50mm -PN10	m	4734				
28	HDPE Pipe 50mm -PN12.5	m	370				
29	HDPE Pipe 50mm -PN16	m	150				
30	HDPE Pipe 63mm -PN6	m	270				
31	HDPE Pipe 63mm -PN10	m	3816				
32	HDPE Pipe 63mm -PN12.5	m	430				
33	HDPE Pipe 63mm -PN16	m	176				
34	HDPE Pipe 75mm -PN6	m	20				
35	HDPE Pipe 75mm -PN10	m	2190				
36	HDPE Pipe 90mm -PN6	m	71				

S. No.	Materials Name	Unit	Quantity	Rate in NRs. (Including transportation/loading/offloading/insurance etc. cost)		Amount	Remark
				In Figure	In Words		
37	HDPE Pipe 90mm -PN10	m	640				
	<b>Fittings</b>						
38	HDPE Saddle with 20mm Branch (25x20)	Pc	90				
39	HDPE Saddle with 20mm Branch (32x20)	Pc	75				
40	HDPE Saddle with 20mm Branch (40x20)	Pc	90				
41	HDPE Saddle with 20mm Branch (50x20)	Pc	70				
42	HDPE Saddle with 20mm Branch (63x20)	Pc	119				
43	HDPE Saddle with 20mm Branch (75x20)	Pc	60				
44	HDPE Saddle with 20mm Branch (90x20)	Pc	15				
45	G.I. Elbow (1/2")	Pc	1004				
46	G.I. Elbow (3/4")	Pc	5				
47	G.I. Elbow (1")	Pc	16				

S. No.	Materials Name	Unit	Quantity	Rate in NRs. (Including transportation/loading/offloading/insurance etc. cost)		Amount	Remark
				In Figure	In Words		
48	G.I. Elbow (1-1/4")	Pc	14				
49	G.I. Elbow (1-1/2")	Pc	22				
50	G.I. Elbow (2")	Pc	41				
51	G.I. Elbow (3")	Pc	1				
52	G.I. Nipple-100mm Long (1/2")	Pc	15				
53	G.I. Nipple-100mm Long (3/4")	Pc	2				
54	G.I. Nipple-100mm Long (1")	Pc	9				
55	G.I. Nipple-100mm Long (1-1/4")	Pc	18				
56	G.I. Nipple-100mm Long (1-1/2")	Pc	37				
57	G.I. Nipple-100mm Long (2")	Pc	43				
58	G.I. Nipple-100mm Long (2-1/2")	Pc	10				
59	G.I. Nipple-100mm Long (3")	Pc	8				
60	G.I. Nipple-300 mm long (1/2")	Pc	476				

*Handwritten signature*

S. No.	Materials Name	Unit	Quantity	Rate in NRs. (Including transportation/loading/offloading/insurance etc. cost)		Amount	Remark
				In Figure	In Words		
61	G.I. Nipple-250 mm long (1/2")	Pc	476				
62	G.I. Nipple-1000 mm long (1/2")	Pc	476				
63	G.I. Socket (1/2")	Pc	506				
64	G.I. Socket (3/4")	Pc	1				
65	G.I. Socket (1")	Pc	1				
66	G.I. Socket (1-1/2")	Pc	1				
67	G.I. Socket (2")	Pc	15				
68	G.I. Socket (2-1/2")	Pc	1				
69	G.I. Socket (3")	Pc	1				
70	G.I. Equal Tee (1/2")	Pc	42				
71	G.I. Equal Tee (1")	Pc	1				
72	G.I. Equal Tee (1-1/4")	Pc	4				
73	G.I. Equal Tee (1-1/2")	Pc	4				



S. No.	Materials Name	Unit	Quantity	Rate in NRs. (Including transportation/loading/offloading/insurance etc. cost)		Amount	Remark
				In Figure	In Words		
74	G.I. Equal Tee (2")	Pc	3				
75	G.I. Equal Tee (2-1/2")	Pc	1				
76	G.I. Equal Tee (3")	Pc	1				
77	G.I. Unequal Tee 1" X 1" X 1/2"	Pc	3				
78	G.I. Unequal Tee 1-1/4" X 1-1/4" X 1/2"	Pc	4				
79	G.I. Unequal Tee 1-1/2" X 1-1/2" X 1/2"	Pc	10				
80	G.I. Unequal Tee 2" X 2" X 1/2"	Pc	12				
81	G.I. Unequal Tee 2-1/2" X 2-1/2" X 1/2"	Pc	1				
82	G.I. Unequal Tee 3" X 3" X 1/2"	Pc	3				
83	G.I. End Cap (1-1/2")	Pc	2				
84	G.I. End Cap (2")	Pc	7				
85	G.I. End Plug (2")	Pc	5				
86	G.I. End Plug (3")	Pc	1				

S. No.	Materials Name	Unit	Quantity	Rate in NRs. (Including transportation/loading/offloading/insurance etc. cost)		Amount	Remark
				In Figure	In Words		
87	GI Reducer 1" x 3/4"	Pc	1				
88	GI Reducer 1" x 1/2"	Pc	1				
89	GI Reducer 1-1/4" x 1"	Pc	2				
90	GI Reducer 1-1/4" x 3/4"	Pc	1				
91	GI Reducer 1-1/2" x 1 1/4"	Pc	1				
92	GI Reducer 2-1/2" x 2"	Pc	1				
93	GI Reducer 2-1/2" x 1-1/2"	Pc	1				
94	G.I. Union 1/2"	Pc	495				
95	G.I. Union 1"	Pc	1				
96	G.I. Union 1-1/4"	Pc	2				
97	G.I. Union 1-1/2"	Pc	7				
98	G.I. Union 2"	Pc	11				
99	G.I. Union 2-1/2"	Pc	1				

S. No.	Materials Name	Unit	Quantity	Rate in NRs. (Including transportation/loading/offloading/insurance etc. cost)		Amount	Remark
				In Figure	In Words		
100	G.I. Union 3"	Pc	2				
101	Tank Nipple (1")	Pc	1				
102	Tank Nipple (1-1/2")	Pc	5				
103	Tank Nipple (2")	Pc	1				
104	Gate Valve (1")	Pc	1				
105	Gate Valve (1-1/4")	Pc	6				
106	Gate Valve (1-1/2")	Pc	10				
107	Gate Valve (2")	Pc	16				
108	Gate Valve (2-1/2")	Pc	1				
109	Gate Valve (3")	Pc	3				
110	Glove Valve (1/2")	Pc	2				
111	Glove Valve (3/4")	Pc	2				
112	Glove Valve (1")	Pc	2				

*Handwritten signature*

S. No.	Materials Name	Unit	Quantity	Rate in NRs. (Including transportation/loading/offloading/insurance etc. cost)		Amount	Remark
				In Figure	In Words		
113	Glove Valve (1-1/4")	Pc	1				
114	Glove Valve (1-1/2")	Pc	3				
115	Glove Valve (2")	Pc	3				
116	Glove Valve (2-1/2")	Pc	1				
117	Float Valve (3/4")	Pc	1				
118	GI/HDPE Flange (40mm x 1-1/4")	Pc	1				
119	GI/HDPE Flange (50mm x 1-1/2")	Pc	22				
120	GI/HDPE Flange (63mm x 2")	Pc	17				
121	GI/HDPE Flange (75mm x 2-1/2")	Pc	5				
122	GI/HDPE Flange (90mm x 3")	Pc	3				
123	Brass Union (20mm x 1/2")	Pc	513				
124	Brass Union (25mm x 3/4")	Pc	1				
125	Brass Union (32mm x 1")	Pc	7				



S. No.	Materials Name	Unit	Quantity	Rate in NRs. (Including transportation/loading/offloading/insurance etc. cost)		Amount	Remark
				In Figure	In Words		
126	Brass Union (40mm x 1-1/4")	Pc	8				
127	Brass Ferrule (1/2")	Pc	499				
128	Brass Tap ( 400g )	Pc	490				
	<b>Tools</b>						
129	Tool box lock (Tala 50mm)	pc	1				
130	Heating plate 5"	pc	1				
131	Teflon cover (7"x7")	pc	15				
132	Thermochrome crayon	pc	10				
133	Blow lamp	pc	3				
134	Knife	pc	4				
135	Teflon tape	pc	250				
136	Pipe wrench 18"	pc	2				

S. No.	Materials Name	Unit	Quantity	Rate in NRs. (Including transportation/loading/offloading/insurance etc. cost)		Amount	Remark
				In Figure	In Words		
137	Pipe wrench 24"	pc	2				
138	Hack saw frame	pc	3				
139	Hack saw blade	pc	30				
140	Adjustable spanner 10"	pc	2				
141	Combination plier 8"	pc	2				
142	Shovel	pc	8				
143	Pick axe	pc	8				
144	Steel pan	pc	8				
145	Crowbar (32mm dia)	pc	3				
146	Sledge hammer 10 lbs	pc	3				
147	Sledge hammer 8 lbs	pc	2				
148	Sledge hammer 1/2lbs	pc	5				
149	Stone cutting hammer	pc	5				

S. No.	Materials Name	Unit	Quantity	Rate in NRs. (Including transportation/loading/offloading/insurance etc. cost)		Amount	Remark
				In Figure	In Words		
150	Stone chisel 6" (32mm dia)	pc	3				
151	Stone Chisel 12" (32mm dia)	pc	3				
152	Building trowel	pc	6				
153	Pointing trowel	pc	6				
154	Finishing trowel	pc	6				
155	Mason string	bdl	6				
156	Plumb bob line	pc	6				
157	Steel brush	pc	3				
158	Soft brush 4"	pc	2				
159	File steel (rough)	pc	4				
160	Spirit level 8"	pc	4				
161	Mason square 6"x12"	pc	4				
162	Measuring tape (3m)	pc	4				

S. No.	Materials Name	Unit	Quantity	Rate in NRs. (Including transportation/loading/offloading/insurance etc. cost)		Amount	Remark
				In Figure	In Words		
163	2mm Wiremesh (2m)	pc	4				
164	4mm Wiremesh (2m)	pc	4				
165	Writing Brush	pc	2				
166	Heating plate 8"	pc	1				
167	Pipe Wrench 36"	pc	2				
168	Measuring Tape (30m)	pc	1				
169	Steel Scissor	pc	2				
170	File Smooth steel	pc	2				
	<b>Fabrication Items</b>						
171	Angle Pole	No	86				
172	Angle Pole for Gate	No	40				
173	Angle Pole for Corner	No	80				

*Handwritten signature*



S. No.	Materials Name	Unit	Quantity	Rate in NRs. (Including transportation/loading/offloading/insurance etc. cost)		Amount	Remark
				In Figure	In Words		
174	Angle Pole for Bracing	No	144				
175	Angle Gate	No	20				
176	Square Slab Frame (small)	No	10				
177	Square Slab Frame (big)	No	28				
178	Square Slab Frame (big) with Metal Cover	No	8				
179	Information Board	No	1				
180	Iron Bracket 1/2"	Pc	21				
181	Iron Bracket 1"	Pc	1				
182	Iron Bracket 1-1/4"	Pc	3				
183	Iron Bracket 1-1/2"	Pc	3				
184	Iron Bracket 2"	Pc	2				
185	Tool box (empty)	pc	1				
186	Tapstand Grid (CI)	No	8				

*Handwritten signature*

S. No.	Materials Name	Unit	Quantity	Rate in NRs. (Including transportation/loading/offloading/insurance etc. cost)		Amount	Remark
				In Figure	In Words		
187	Slab frame key	pc	8				
<b>Total Amount</b>							
VAT 13%							
<b>Grand Total</b>							
In words: .....							
.....							

Authorized signature: \_\_\_\_\_

Name: \_\_\_\_\_

Designation: \_\_\_\_\_

Company Seal/stamp: \_\_\_\_\_

Date: \_\_\_\_\_



*Handwritten signature*

## 6. SCHEDULE OF REQUIREMENTS (SOR)

The purchaser will strictly monitor that the schedule of requirements is fully honored by the supplier and shall assess the performance of the supplier in view of adherence to it.

### 6.1 DELIVERY PLACE AND SCHEDULE

The goods shall be delivered in the following manner:

Sn	Scheme's Name	Delivery Place	Estimated distance	Delivery Schedule in days after signing the contract agreement
1.	Lekbeshi ward no 3 DWS	Lekbeshi-3 Byaure Dashrathpur, Surkhet	Chinchu to Byaure Dashrathpur around 30 km (15 km blacktop and 15 km gravel) <b>Alternative way</b> Birendranagar to Byaure Dashrathpur around 25 km (gravel road)	45 Days

### 6.2 NOTICE OF DELAY

In the event that the Supplier encounters a delay in supply of the goods, the Supplier shall promptly notify the Purchaser of such delay with proper evidence and may request for time extension before expiry of the time given in the contract.

### 6.3 TIME EXTENSION

Time extension request shall be considered by the Purchaser only in exceptional case if the reasons are acceptable to the Purchaser.

### 6.4 PENALTIES FOR DELAY

In case of delay in the delivery of the goods, due to Supplier's default, beyond the time specified in the contract, the penalty will be determined as per the conditions of contract.

### 6.5 EMPLOYMENT

The Supplier shall employ exclusively local skilled/unskilled labours. Helvetas Nepal requires that tender, contractors and suppliers ensure during the procurement and execution of such contracts that people in the supply-chain are treated with respect and have rights with regard to employment including the rights to freely choose employment, freedom of association, payment of a living wage, working hours that comply with national laws, equal opportunities, recognized employment relationship, freedom from intimidation and to a safe and healthy working environment. Equally, contractors must ensure that there shall be no exploitation of child and forced labour. This shall be ensured in terms of the ILO Convention No. 182 on the Worst Forms of Child Labour, 1999 and the ILO Convention No. 138 on the Minimum Age for Admission to Employment and Work, 1973.

### 6.6 GENDER

No discrimination for wage payment will be made on the basis of gender or caste or ethnicity.

### 6.7 EQUITY

The Supplier shall pay equal wage for equal work.

### 6.8 INSURANCE

The supplier shall procure insurance policy for all the personnel working in supply of goods.



## 7. SPECIFICATIONS & QUALITY ASSURANCE

### 7.1 QUALITY OF MATERIALS

The materials supplied and used in the works shall comply with the requirements of these Specifications. The materials/goods shall be manufactured, handled and used skillfully to ensure completed works to comply with the contract.

### TECHNICAL SPECIFICATION

SN	Name of goods and related services	Required Specification
1	High density polythene (HDPE) pipe of nominal outside diameter DN 20,25,32,40,50 63,75 90,110, 125, 140,160, 200mm	Nominal outer diameter DN (20, 25, 32, 40, 50, 63, 75, 90, 110, 125, 140, 160, 200mm) of HDPE Pipe of pressure rating from PN6 PN 10, PN12.5 and PN16 manufactured and packing as stickily as per NS-40 fourth edition 2074
2	G.I. Pipe (MC):	Manufactured strictly as per the specification of Nepal Standard (NS-199), medium class Tensile Strength – 25 kg per sq cm2 after 7 days Compressive Strength – 220 kg/cm2 after 7 days, IS or equivalent
3	G.I. Pipe (High class)	Manufactured strictly as per the specification of Nepal Standard (NS-199), high class
4	Gate Valve	Gunmetal/Brass wedge gate valves, rising stem, hand-wheel operated with screwed female ends, conforming to NS. Female connection threads to BS 21 or IS 544-1975 NS or as per sample provided
5	Float valve: Size (½" to 1½") for break pressure chamber (BPT type)	Float valve shall be of heavy-duty type for break pressure chamber with pressor rating shall be 10kg/cm2. well-known heavy and high-class quality construction, reliable operation even at higher working pressure with assembled complete set of copper ball and back check nuts. Or, as per sample Provided
6	Air valve: Size ½ & ¾"	Materials; Bronze, - Maximum operating pressure will be 10 kg/cm2 Connection; male threads to BS 21, Or as per sample
7	Brass Union for joining HDPE & GI pipes: Adapter Type	HDPE pipes as per NS-40: 2049 High density polyethylene pipe with fourth edition 2074, minimum 10 kg/cm2 pressure rating GI pipes to Nepal Standard (NS -199) or equivalent, GI pipes with male threads Component: brass body, nut, adaptor, washer. each set to be supplied assembled, Or as per sample
8	Brass Tap 400g	Brass Tap shall be nominal 15 mm diameter conforming to NS. Inlets shall be male screwed suitable for joining to 15 mm GI socket.

SN	Name of goods and related services	Required Specification
		Outlet shall be plain ended. - Top shall be round turned crutch. NS or as per sample provided
9	Ferule Cock ½" -heavy duty	Ferrule for household connection from main supply pipe having regulating device made of high-quality brass or gunmetal. Size required: ½" regulating tee having tightening screws & handle with adjusted end, NS or as per sample
10	Globe Valve	Shall be gunmetal or Brass, rising stem, handwheel operated with screwed female ends with screwed female ends, conforming to NS. Female connection threads to BS 21 or IS 544-1975, NS or as per sample provided
11	Standard G.I Fittings (Socket, Elbow, Equal and Unequal Tee, Reducers etc.)	Standards: NS 383- equivalent to IS 1879-1987 (second revision) Malleable iron fittings with white iron-carbon alloy. Materials: the quality of metal shall be either white heart or black heart malleable casting Threads: Threaded as per IS 554-1975 (second revision) parallel female and upper male thread Dimension and weight: as per IS 1879-1987. The fittings shall be ribbed and also reinforced in the form of band conform to the table 1,2 or IS 1879-1987. Finish Surface: hot dip galvanized. Working pressure: Max permissible 2.5 MPa Marking: The standard mark as governed by Nepal standard so far applicable. Manufacturer's name or trademark & size
12	GI Nipples	GI Nipple, male, to be manufactured of medium duty BS 1387;1967 for pipe "pieces" with approx. standard length of 10cm should be well threaded
13	End cap	G.I. end cap heavy duty well threaded, best quality
14	GI Union	GI Union, flat seat, female (to be supplied fitted with a gasket) conforming to NS or equivalent
15	Tank nipple	Hot Dip Galvanized for water piping Installations, with well threaded, having good washer in both side or best quality or as per sample
16	HDPE Saddle	IS: 800 (Part I – VII) -1976 or equivalent to join HDP pipes to IS: 4984 – 1978 or equivalent or as per sample.
17	Flange set GI/HDPE	Flange set to join HDP pipe as per IS : 4984 - 1978 or equivalent to IS : 1239 (Part I) – 1990 or BS : 1387 - 1967 GI pipe (make threads) shall consist of : female threaded flange, plain unthreaded flange, HDP flange adaptor, duty rubber gasket and nuts, bolts and washers Flange set to join IS 4984- 1978 or NS-40: 2049 High density polyethylene pipe with fourth edition 2074 to BS 1387-1967 GI pipes (male threads) Consisting;



SN	Name of goods and related services	Required Specification
		Female threaded flange, Plain unthreaded flange, HDPE flange adapter, Rubber gasket Nut, bolts and washers (adequately tightened) Size greater than 3 inches, should have 8 number of nut and bolt system
18	Flange set GI/GI	Threaded flanges MS Galvanized 4 holes Conforming to BS 10 Table E, With Rubber Gasket with nut & bolts or As Sample
19	Cement OPC (NS)	Manufactured strictly as per the specification of Nepal Standard (NS-49 -second review) for OPC cement or equivalent. The OPC cement should have minimum compressive strength 53 MPa in 28 days. The bidder must submit test certificate for the product confirming the material to be supplied is of NS-49-second revision and should be tested as per IS 4031. The cement should not be manufactured before 3 months on the date of delivery The bags should be sealed with manufactures unbroken seal and should clearly mentioned the date of packing, brand name and weight
20	Rebar (ms-rod/bar) 8mm, 10mm & 12mm	NS 191, should be deformed and able to develop perfect bond, easy to cut, bend, bind or weld and having high tensile strength
21	Binding wire	best quality or as per sample
22	Plain wire (H)	3.5mm dia. wire; galvanized, easy to cut, bend, bind or weld and having high tensile strength
23	Barbed wire	NS or ISO 9001:2000, Wire dia. 12 gauge & galvanized
24	Cement Paint (Snowcem)	white color, shall be in powder form, packing in 20kg free from organic materials, sealed container with best quality
25	Chicken wire mesh	90cm width; wire dia. 22 gauge, Hexagonal in shape; mesh size- 15mmx15mm
26	Polythene Sheet	Best quality, Thickness 300 microns or as per provided sample
27	Gate Lock (tala 50mm)	50mm, Material: brass or steel, best quality
28	Nut with bolt (8mm dia)	8mm: Galvanized, best quality or as per sample provided
29	Nails 2"	2" long, hammering head with tapered pin
30	Suspension Cable (8mm 10mm & 12mm)	Steel wire ropes should comply with all the requirements for IS 1835 - 1977 with confirming following lubrication process. Lubrication should be non-drying and non-bituminous type confirming to IS: 9182-1979. Lubrication must be applied during manufacturing of the rope. Lubrication should withstand temperature up to 75 ° C (Drop Point). It should withstand storing at open atmosphere in touch with the ground and in inundation condition for a long duration and should prevent any kind of rust or as per sample provided.

SN	Name of goods and related services	Required Specification
31	Bulldog Grip (8mm, 10mm & 12mm)	Bulldog grips should confirm to: IS: 2361 - 1970, specification for bulldog grips with fulfill the following requirements: Grips, U-bolts, and nuts should be hot dip galvanized with minimum zinc coat as per standard, Recommended Practice for Hot Dip Galvanizing of Iron & Steel, Electroplated galvanization is not acceptable, the thread of U-Bolt and nuts on it should withstand specified torque. Should have minimum grip strength as per IS standard or as per sample provided
32	Machine Made Gabion Box:	machine made Gabion boxes heavy coated having 10cmX12cm double twisted hexagonal mesh type of 3.00mm mesh wire dia
33	Heating plate (5" & 8")	Chromium plated steel plate diameter 125mm, thickness 15mm, Handle 450mm long with well-seasoned wooden, Handle joint to plate by welding, or as per sample. Chromium plated steel plate diameter 203.20mm, thickness 15mm, Handle 450mm long with well-seasoned wooden, Handle joint to plate by welding, or as per sample
34	Pipe Wrench (10", 14", 18", 24", 36")	Length as per specified, Stillson pattern, malleable carbon steel, polished, Brand -Venus or Ludhra or TATA or as per provided sample
35	Adjustable Wrench	10" long, malleable carbon steel handle, Floating upper jaw, Brand - Taparia or Venus or as per provided sample
36	Combination Plier	Length-205 mm; fine grip with joint cutter, Handle insulated, Brand – Taparia or Venus or as per provided sample
37	Shovel	IS 274 (part I) 1981, Round-nose shove type, - with Metal handle or as per provided sample
38	Pickaxe	To be supplied with well-seasoned wooden handle fitted, Wt 2.5 kgs without handle
39	Steel pan	Metal sheet minimum thickness 1.5 mm, pan diameter 45cm with banded edge, Quality of metal sheet should be as per provided sample
40	Crowbar	32mm dia. hexagonal crowbar with chisel & hammer end, width across flats 32mm, length 5 ft., TATA or Ludhra or as per provided sample
41	Sledgehammer (½ lbs to 10 lbs)	To be supplied with fitted and well-seasoned wooden handle, Double face hammered end, Brand - TATA or Ludhra or as per provided sample
42	Stone cutting hammer	Forged, tempered steel, Length-13cm, hammer end-4cm x 4cm & edge –3cm, Weight-1.5 kg, 20mm dia hole for handle below 4cm from the top, Brand - TATA or Lundhra or as per provided sample
43	Stone chisel (12" & 6")	Octagonal with chisel having 32mm dia. and hammer end width across flat 32mm for 12"

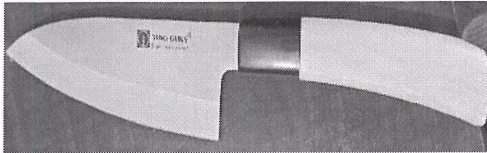
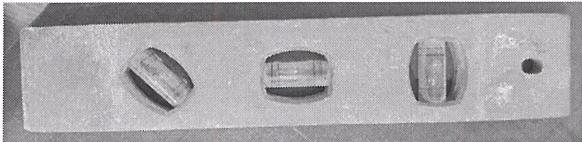

SN	Name of goods and related services	Required Specification
		Octagonal with chisel having 32 mm dia. and hammer end width across flat 32mm for 6" Brand - TATA or Ludhra or as per provided sample
44	Trowel Building	Length-20cm, breadth at the mid-12cm and tapered gradually towards both ends, Well-seasoned wooden handle fitted well in trowel plate and anchored well at other end; steel plate thickness- 1 mm and surface should be completely smooth
45	Trowel pointing	Length-12cm, breadth at the mid-5cm and tapered gradually towards both ends, Well-seasoned wooden handle fitted well in trowel plate and anchored well at other end -1 mm and surface should be completely smooth
46	Trowel finishing	Rectangular in shape; length-25cm, breadth-10cm, Plastic handle fitted well middle portion and at backside; steel plate thickness-0.7 mm & surface should be completely smooth
47	Teflon tape	20mm wide to be used for joining threaded GI pipe, for drinking water purpose. To be supplied on plastic spool containing 20m Teflon tape
48	File steel (rough)	Size:300mm x 30mm; Flat, Both side grip
49	Mason Square 6"x12"	Steel Brush: best quality
50	Soft brush 4"	Size: 100mm with wooden handle, best quality
51	Plumb bob line	Smooth finishing surface, Conical base, 40mm dia. base; length 40mm, Screwed string fixing mechanism
52	Mason string	Cotton string; Weight-100gram, Best quality
53	Measuring tape 3m	best quality
54	Knife	Heavy duty stainless steel, butcher type, minimum length of cutting edge 5cm with handle or as per sample 
55	Spirit level 8"	8" long, precision levels with perfectly straight sides, Shock resistant and cannot be deformed,  Unbreakable vials in machined plastic, or as per sample provided
56	Mason square 6"x12"	as per sample
57	2mm Wiremesh (2mtr pc):	22 gauge steel mesh wire having 2mm square clear windows, 90cm height
58	4mm Wiremesh (2mtr pc)	22 gauge steel mesh wire having 4mm square clear windows, 90cm height
59	Measuring Tape (30m)	best quality

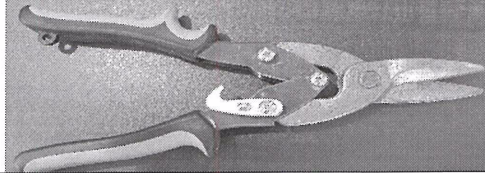

SN	Name of goods and related services	Required Specification
60	Steel Scissor	as per sample provided 
61	Teflon cover(7"x7")	Heat resistant Teflon bag, size (150mm×150mm)/ to fit to heating plate diameter 125 mm/254mm and thickness should be as per provided sample, Thread used for sewing must be of Teflon
62	Thermochrome crayon	Can withstand maximum temperature of 2200 C, Colour – green
63	Hack saw frame	Adjustable to Hacksaw blade 300 mm
64	Hack saw Blade	300 mm long, 2 side teeth, 12mm wide
65	Toolbox lock (tala 50mm)	50mm, Material: brass or steel, best quality
66	Angle pole	Steel angle size 40mm x 40mm x 5mm; length 200cm. Black Japan paint coated after red oxide coat. Nos. of holes & spacing as per attached drawing. Smooth finishing, as per attached drawing
67	Angle pole for gate	Steel angle size 40mm x 40mm x 5mm; length 200cm. Black Japan paint coated after red oxide coat. Nos. of holes & spacing as per attached drawing. Smooth finishing, as per attached drawing
68	Corner Pole	Steel angle size 40mm x 40mm x 5mm; length 200cm. Black Japan paint coated after red oxide coat. Nos. of holes & spacing as per attached drawing. Smooth finishing, as per attached drawing
69	Bracing Pole	Steel angle size 40mm x 40mm x 5mm; length 190cm. Black Japan paint coated after red oxide coat. Nos. of holes & spacing as per attached drawing. Smooth finishing, as per attached drawing
70	Angle Gate	Steel angle size 40mm x 40mm x 3mm Black Japan paint coated after red oxide coat. Steel bar spacing and design as per attached drawing. Smooth finishing & excellent welded joint, as per attached drawing
71	Tap stand Grid	Size 18cm x 25 cm; plate thickness 2mm and breadth 20mm, Black Japan paint coated after red oxide coat. Design and spacing as per attached drawing, Smooth finishing & excellent welded joint, as per attached drawing
72	Square Slab Frame (750x750mm inner size) Big Slab Frame Type I	Outer & inner square frames, Outer for fixing and Inner removable, Male outer frame size: 81.5x81.5 cm & Female outer frame size: 84.0x84.0cm, Steel angle size 40mm x 40mm x 3mm, Black Japan paint

SN	Name of goods and related services	Required Specification
		coated after red oxide coat, Smooth finishing & excellent welded joint, as per attached drawing.
73	Square Slab Frame (550x550mm Inner size) Small Slab Frame Type II	Outer & inner square frames, Outer for fixing and Inner removable, Male outer frame size: 61.5x61.5 cm & Female outer frame size: 63.0x63.0cm, Steel angle size 40mm x 40mm x 3mm, Black Japan paint coated after red oxide coat, Nos. of holes & spacing as per attached drawing. Smooth finishing & excellent welded joint, as per attached drawing
74	Slab Frame Key	Made of best quality 10mm MS plain bar, Black Japan paint coated after red oxide coat, Smooth finishing, as per attached drawing.
75	Information Board	Size – 3 ft × 4ft, Sheet – 20 gauge (black iron sheet) Angle frame – 25mm×25mm×3mm Vertical Support: 32 mm dia. Or 1¼” GI Pipe (MC) Length of support/32mm dia GI Pipe: 10 ft 2 nos
76	Toolbox with tray	Size 600×280×280mm minimum, with lock Material: 1mm thick steel plate, blue enamel painted, locally made
77	Bracket	as per provided sample
78	Square Slab Frame (750x750mm) with Metal Cover	Outer & inner square frames, outer for fixing and inner removable, Male outer frame size: 81.5x81.5 cm & Female outer frame size: 83.0x83.0cm, Steel angle size 40mm x 40mm x 3mm, Metal frame 85.0cm x 85.0cm x 0.2cm Black Japan paint coated after red oxide coat, Smooth finishing & excellent welded joint, As per attached drawing.

### Drawings

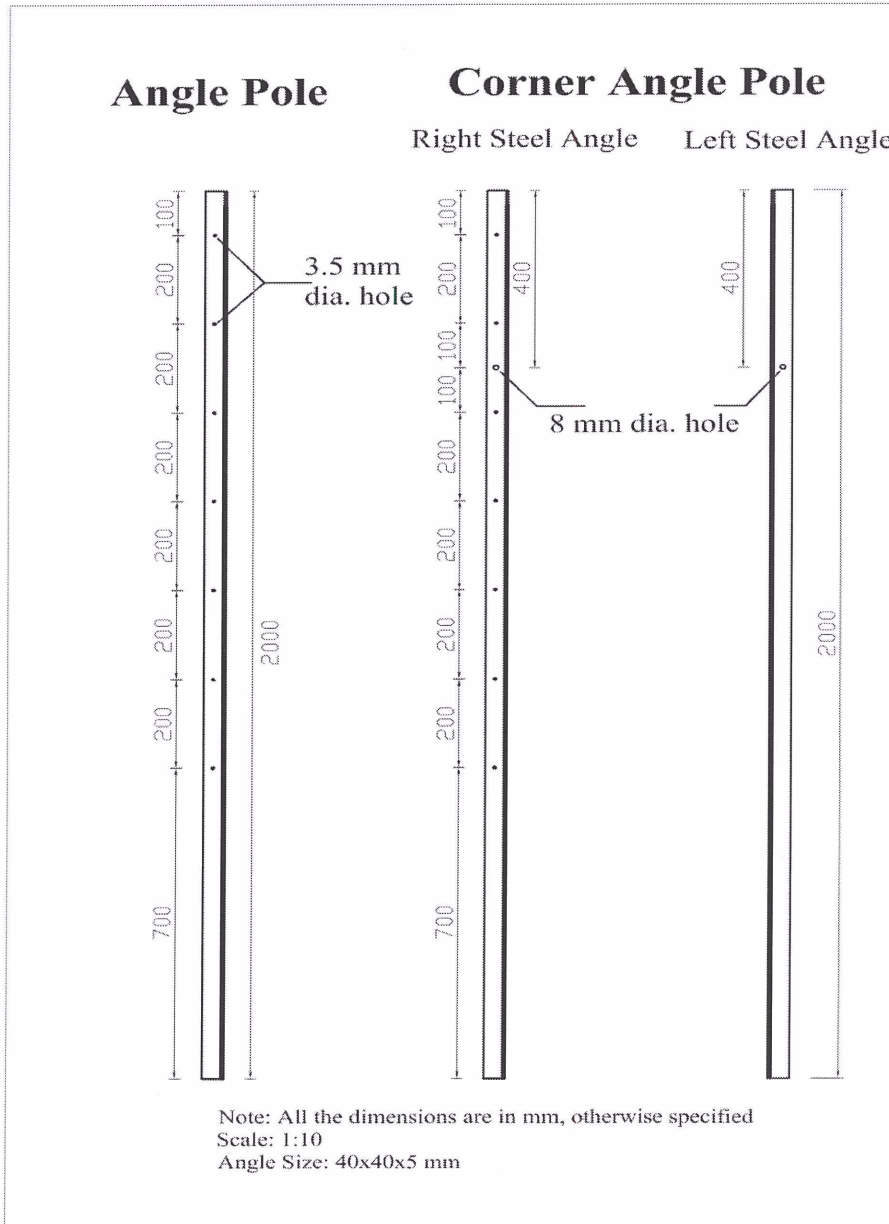



## Bracing Angle Pole

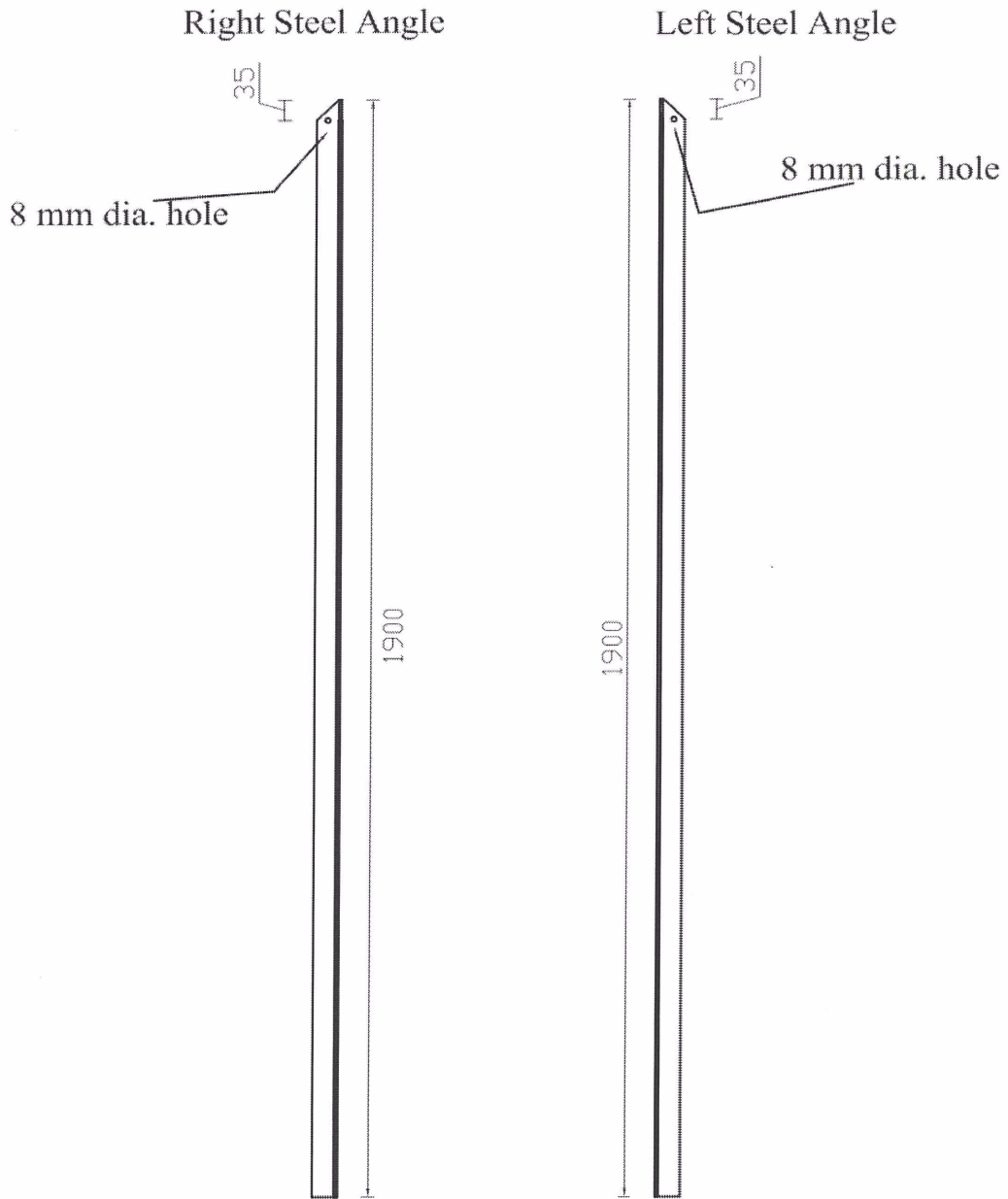

Note: All the dimensions are in MM, otherwise specified  
Scale: 1:10  
Angle Size: 40x40x5 mm

## Angle Gate

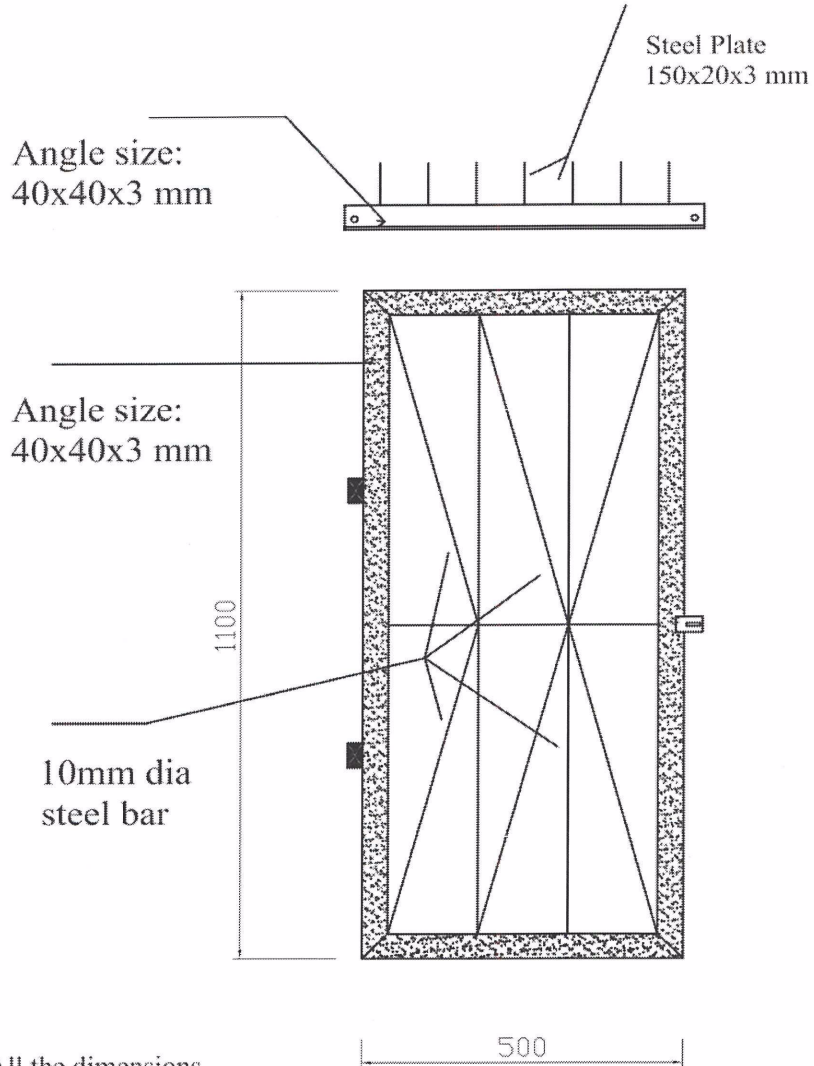

Note: All the dimensions are in MM, otherwise specified

Scale: 1:10

# Assembly of Angle Gate

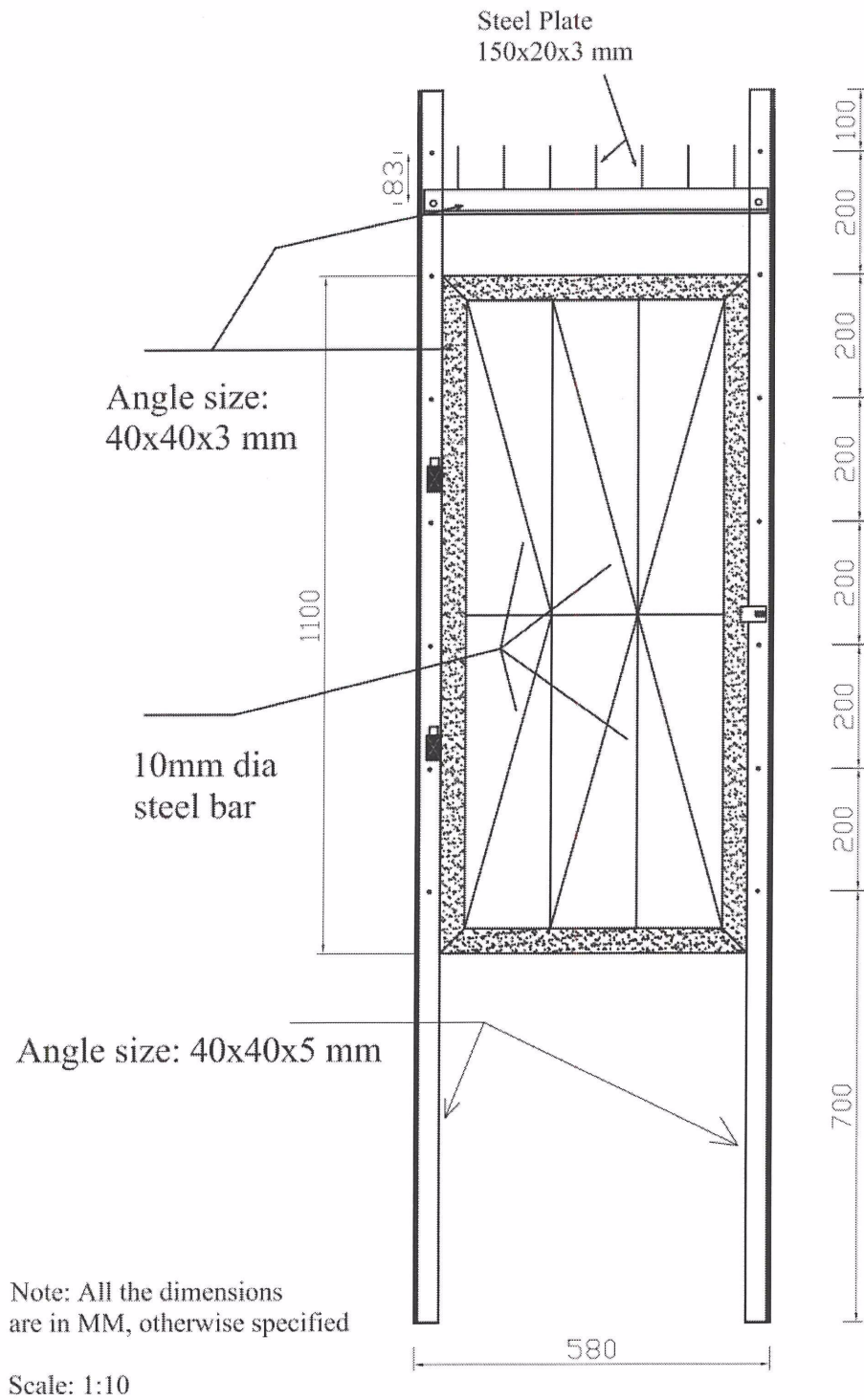



MPN

### Square Slab Frame (Small)

Outer Frame  
Angle Size: 40x40x3 mm

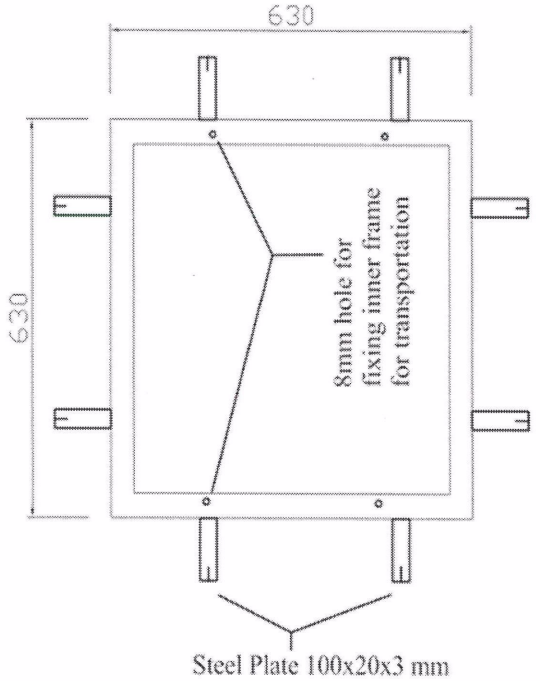

Inner Frame  
Angle Size: 40x40x3 mm

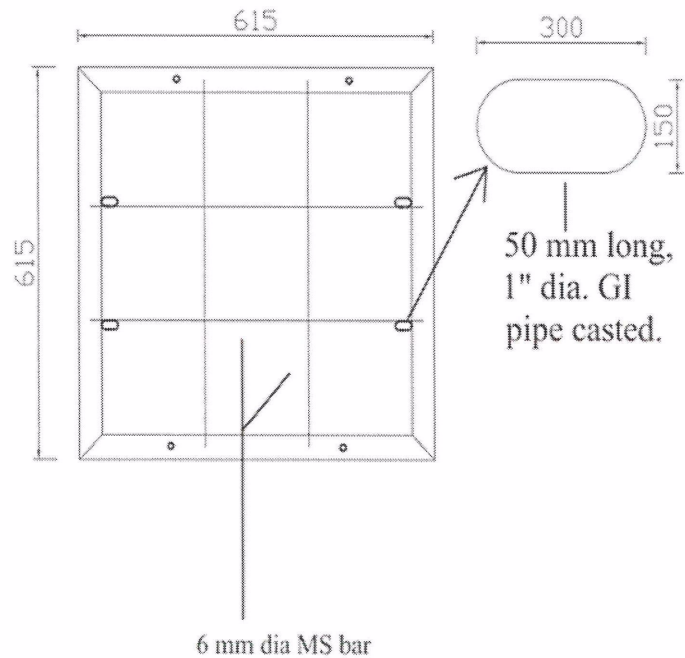

Note: All the dimensions are in mm, otherwise specified  
Scale: 1:10

HR

### Square Slab Frame ( BIG )

Outer Frame  
Angle Size: 40x40x3 mm

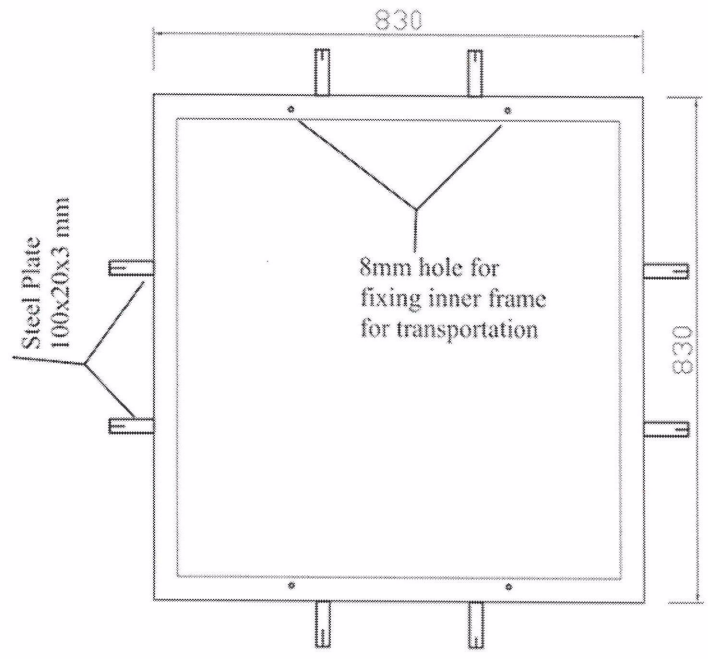

Note: All the dimensions  
are in mm, otherwise specified

Scale: 1:10

Inner Frame  
Angle Size: 40x40x3

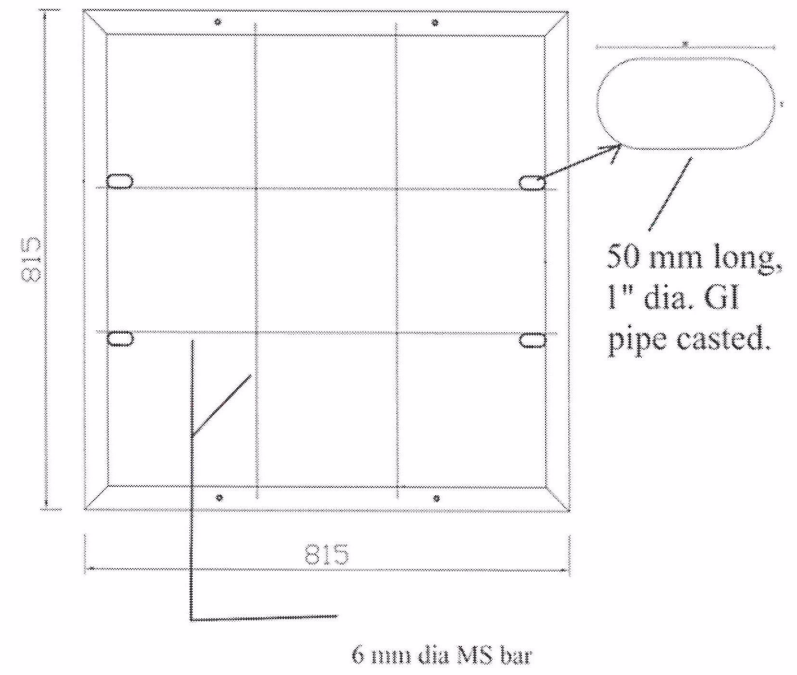

## Tap Stand Grid

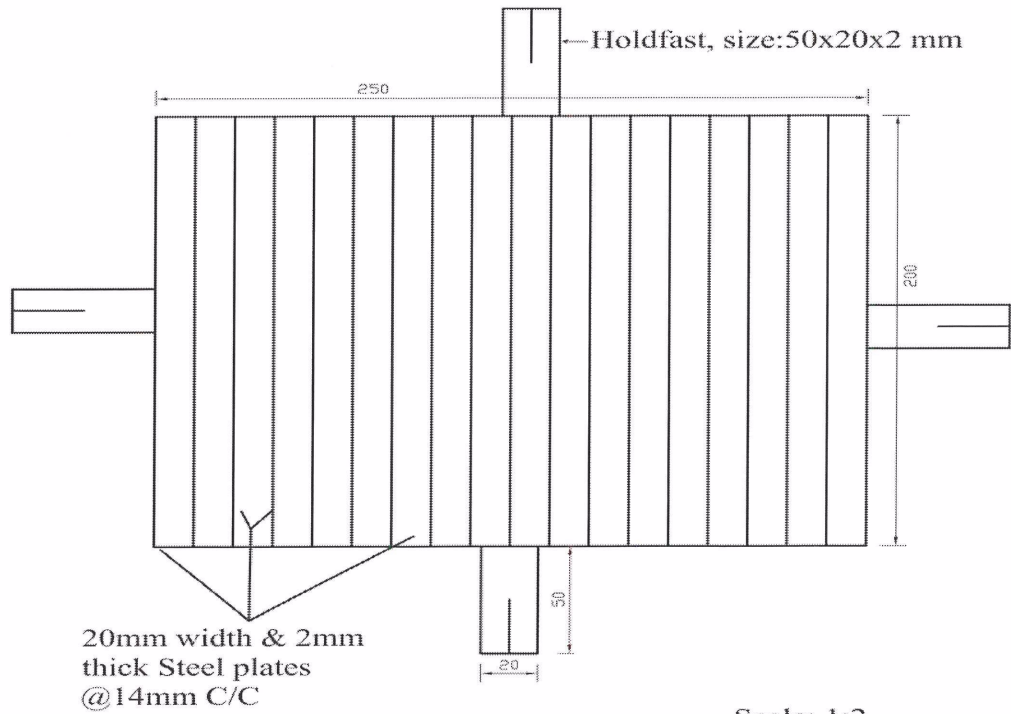

Scale: 1:2

## Iron Bracket 1/2" & 3/4"

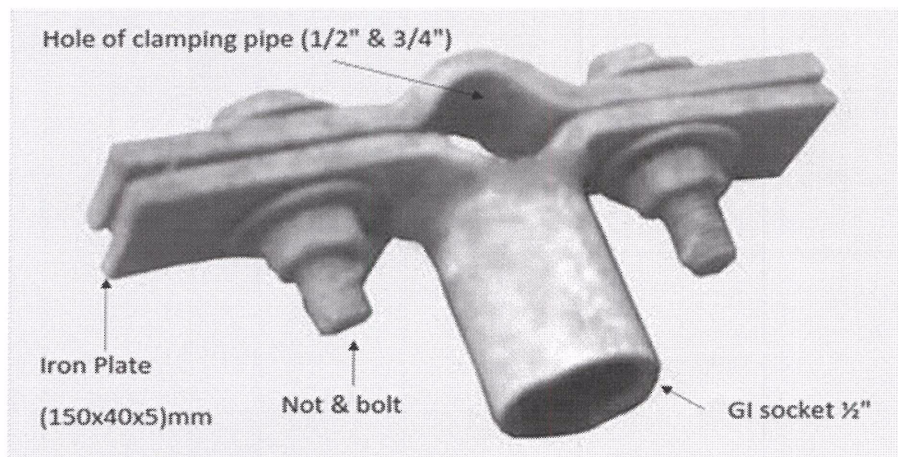



## Slab Frame Key

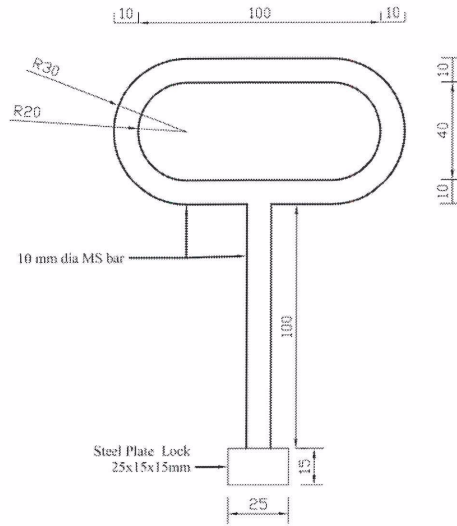

Scale: 1:2

## Top View of Steel Plate Lock

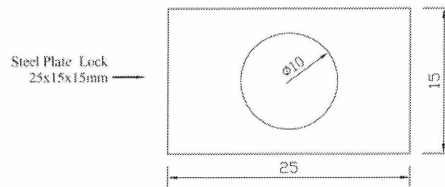

Note: Not to the scale

Note: All the dimensions are in mm otherwise specified.

AA  
ABN



**HELVETAS**  
NEPAL



## 7.2 SOURCES OF MATERIALS

The use of any one kind or class of material from the source is to be approved. The sources or kinds of material shall not be changed without written permission of the Engineer. If the product of any source proves unacceptable, the supplier shall make necessary arrangements for the supply of acceptable material. Any claims for compensation associated with such arrangements or changes shall not be considered, unless the source of the unacceptable material is designated in the contract as a source of material.

## 7.3 QUALITY REQUIREMENTS, QUALITY CONTROL AND QUALITY ASSURANCE (GUARANTEE)

The quality control of the materials acquired, is the responsibility of the prime Supplier, who should guarantee that all materials are of standard quality according to the specifications given are correct according to Design and Drawings. The cost for all damages due to use of low-quality materials has to be borne by the Supplier. At the time of delivery, the parts and materials shall have to be free from any defects in material or workmanship in all respects and shall remain reasonably perfect till the end of maintenance period when a final check shall be carried out.

## 7.4 INSPECTION, TESTS AND FINAL CHECK

The Supplier shall coordinate to provide access and other facilities for the inspection and, if required, tests of the materials. Such inspection shall be made prior to delivery or at time of delivery at destination and shall be conducted so as not to interfere unnecessarily with the operation of other work. Such inspections are supplementary and intended to clear the delivery only and shall not be considered as a final acceptance.

The final check of all materials will be conducted, and the discrepancies found during such final check have to be rectified by the supplier at its own cost. On a default situation, such works shall be conducted by the Purchaser and the cost incurred for such works shall be made a liability in the supplier's account (either from other payments and/or their property according to the prevailing rules and regulations).

The inspector may at his/her discretion check the test results obtained at the Supplier's works by independent tests and should the material so tested be found to be unsatisfactory, the costs of such tests shall be borne by the supplier, and, if satisfactory, the costs shall be borne by the Purchaser. In any case the quality assurance by the Supplier has to be made available, whenever required by the Purchaser.

## 7.5 TRANSPORTATION

It is the responsibility of the Supplier to control transportation activities and quality/quantity of any materials, loading and off-loading of the same, and the delivery at designated point. The Supplier shall entirely be responsible for the quality and quantity of materials received at the point of origin and their delivery at designated point in the same quantity and quality. No reasons whatsoever will be accepted for materials not reaching to site in proper condition and in required quantity. Loss during transportation, if any is entirely on the Supplier's account. Work being delayed because of materials being damaged during transportation is Supplier's concern, which shall not be considered a reason for the time extension.

## 7.6 HEALTH AND SAFETY

The handling staff from supplier shall be equipped with application of full safety equipment's such as gloves and sturdy boots to prevent injury, and that a first aid package is available at loading and off-loading locations



## 8. GENERAL CONDITIONS OF CONTRACT (GCC)

- 1. Definitions**
- 1.1 In this contract, the following terms shall be interpreted as indicated:
- a. "The Contract" means the agreement entered between the Purchaser and the Supplier and signed by both the parties and it includes all attachments and appendices thereto and all documents incorporated by reference therein.
  - b. "The Contract Price" means the price payable to the Supplier under the contract for the full and proper performance of its contractual obligation.
  - c. "The Goods" means Equipment and related Accessories and spare-parts or any other materials which the Supplier is required to supply to the Purchaser under the contract.
  - d. "The Services" means the works described in the Terms of References to be performed by the supplier including modification, alteration, and additions of works and other obligations of the supplier covered under the Contract.
  - e. "The Purchaser" means the procuring entity purchasing the goods.
  - f. "The Supplier" means the organization supplying the goods and services under this contract.
  - g. "Engineer" or "The purchaser's representative" means the engineer appointed by the purchaser from time to time for inspection/supervision of goods and services.
  - h. "The Delivery Site" means the place or places where delivery of the goods is to be made. It is also to be referred as "destination point".
  - i. "Terms of Reference" means the schedule of works and duties, defined by the bidding document and to be executed by the supplier under this contract.
- 2. Application** These General Conditions shall apply to the extent that they are not superseded by provisions in other parts of the contract.
- 3. Standards**
- 3.1 The Goods supplied under this Contract shall conform to the standards mentioned in the **Technical Specifications**,
- 3.2 Wherever reference is made in the **Technical Specifications** to specific standards and codes to be complied with, the specified standards and codes shall apply and the provisions of the latest edition or revision of the standards or codes shall apply only with the pre-consent of the Purchaser.
- 4. Use of Contract Documents and Information**
- 4.1 The Supplier shall not, without the Purchaser's prior written consent, disclose the Contract, or any provision thereof, or any specification, plan, drawing, pattern, sample, or information furnished by or on behalf of the Purchaser to any person other than a person employed by the Supplier for performing the Contract. Disclosure to any such employed person shall be made in confidence and shall extend only so far as may be necessary for purposes of such performance.
- 4.2 The Supplier shall not, without the Purchaser's prior written consent, make use of any document or information except for purposes of performing the Contract.
- 4.3 Any document, other than the Contract itself, shall remain the property of the Purchaser and shall be returned (all copies) to the



- Purchaser on completion of the Supplier's performance under the Contract, if so, required by the Purchaser.
- 5. Patent Rights** The Supplier shall indemnify the Purchaser against all third-party claims of infringement of patent, trademark, or industrial design rights arising from use of the Goods or any part thereof.
- 6. Inspections and Tests**
- 6.1 The Purchaser or its Representative shall have the right to inspect and/or to test the goods at its own costs. The Purchaser shall notify the Supplier in writing of the identity of any representatives retained for these purposes.
- 6.2 The inspections and tests can be conducted on the premises of the Supplier or its sub-Supplier(s) and/or at the Goods' destination. If conducted on the premises of the Supplier or its sub-Suppliers(s), all reasonable facilities and assistance, including access to drawings and production data, shall be furnished to the inspectors at no charge to the Purchaser.
- 6.3 Any inspected or tested Goods fail to conform to the Specifications, the Purchaser may reject the Goods, and the Supplier shall either replace the rejected Goods or make alternations necessary to meet specification requirements, free of cost to the Purchaser.
- 6.4 Nothing in GCC shall in any way release the Supplier from any warranty or other obligations under this Contract.
- 6.5 A Certificate of Acceptance shall be issued by the Purchaser after necessary inspection and tests of the Goods in case the goods conform to the specifications and drawings.
- 7. Packing**
- 7.1 The Supplier shall provide such packing of the Goods as is required to prevent their damage or deterioration during transit to their destination, as indicated in the Contract. The packing shall be sufficient to withstand, without limitation, rough handling during transit and exposure to extreme temperatures, salt and precipitation during transit, and open storage. Packing case size and weights shall take into consideration, where appropriate, the remoteness of the Goods' destination and the absence of heavy handling facilities at all points in transit.
- 7.2 The packing, marking and documentation inside and outside the packages shall comply strictly with such special requirements as delineated instructed by the Purchaser.
- 8. Insurance** The goods supplied under this Contract shall be fully insured against loss or damage incidental to manufacture or acquisition, transportation, storage, and delivery. Such insurance shall be arranged and paid for by the supplier.
- 9. Transportation**
- 9.1 The Supplier shall be required to meet all transport and storage expenses until delivery.
- 9.2 Transportation of the goods after delivery at the destination point shall be the responsibility of the Purchaser
- 10. Incidental Services** The Supplier may be required to provide incidental services, including additional services, if any.
- 11. Warranty**
- 11.1 The Supplier warrants that the Goods supplied under the Contract are new and unused. The Supplier further warrants that all Goods supplied under this Contract shall have no defect, arising from design, materials, or workmanship or from any act or omission of the Supplier.
- 11.2 The warranty shall remain valid for (12) months after the delivery of the goods at the destination point indicated in the Contract to the satisfaction of the Purchaser.

- In case any defect is observed or found in the goods at the site, the supplier shall be liable to bring back the defective goods and shall replace them with proper ones at his/her own costs.
- 11.3 The Purchaser shall promptly notify the Supplier in writing of any claims arising under this warranty.
- 11.4 Upon receipt of such notice, the Supplier shall, within the period specified and with all reasonable speed, repair or replace the defective Goods or parts thereof, without costs to the Purchaser.
- 11.5 If the Supplier, having been notified, fails to take remedial action within fifteen (15) days from date of receipt of notice, the Purchaser may proceed to take such action as may be necessary, at the Supplier's risk and expense and without prejudice to any other rights which the Purchaser may have against the Supplier under the Contract.
- 12. Payment and Taxes**
- 12.1 After acceptance of the goods by the purchaser and their delivery at the destination point, payments shall be made by the Purchaser, within 15 days. The full and final payment shall be made only after completion of delivery. The purchaser may consider part payment based on delivery upon request of the supplier and if deemed essential on mutual understanding.
- 12.2 All taxes applicable shall be for the Supplier's account.
- 12.3 VAT shall be explicitly mentioned on the invoice and shall be for the Purchaser's account.
- 13. Prices**
- 13.1 Prices charged by the Supplier for goods under the Contract shall not vary from the prices quoted by the Supplier in its bid.
- 14. Order Placement**
- 14.1 The Purchaser may place the order on lot basis in a written form to the suppliers.
- 14.2 Actual contract size, quantity, duration etc. can be done in accordance with clauses of contract (refer SCC).
- 14.3 The order size will be confirmed at the time of order placement. (refer SCC).
- 14.4 Additional order: the purchaser can place order for additional quantity within price validity period under this agreement if required.
- 15. Contract Amendments**
- 15.1 Duration of contract may be extended by mutual understanding without affecting the agreed quality and cost.
- 15.2 Price validity of original contract may be extended by mutual understanding of contracting parties.
- 16. Assignment**
- The Supplier shall not assign to a third party, in whole or in part, its obligations to perform under the Contract, except with the Purchaser's prior written consent.
- 17. Subcontracts**
- The Goods/Services shall be fully supplied/performed by the Supplier and shall strictly abstain from sub-contracting in whole or any portion of the goods/services to any other supplier other than other than the partners mentioned in Bid Form.
- 18. Delays in the Supplier's Performance**
- 18.1 Delivery of the goods and performance of services shall be made by the Supplier in accordance with the time schedule specified by the Purchaser in the **Schedule of Requirement**.
- 18.2 An unexcused delay by the Supplier in the performance of its delivery obligations shall render the Supplier liable to any or all of the following sanctions: imposition of liquidated damages, termination of the Contract and /or disqualification up to a period of two years.
- 18.3 If at any time during performance of the Contract, the Supplier should encounter conditions impeding timely delivery of the



- goods and performance of Services, the Supplier shall promptly notify the Purchaser in writing of the fact of the delay, its likely duration and its cause(s). As soon as practicable after receipt of the Supplier's notice, the Purchaser shall evaluate the situation and may, at its discretion, extend the Supplier's time for performance, with or without liquidated damages.
- 19. Liquidated Damages** If the Supplier fails to deliver any or all of the goods or to perform within the time period(s) specified in the Contract, the Purchaser shall, without prejudice to its other remedies under the Contract, deduct from the Contract Price, as liquidated damages, a sum equivalent to 0.25% of the contract price of the delayed goods for each day of delay until actual delivery, up to a maximum deduction of (10%) percent of the Contract Price. Once the maximum is reached, the Purchaser may consider termination of the Contract.
- 20. Termination for Default**
- 20.1 The Purchaser may, without prejudice to any other remedy for breach of Contract, by written notice of default sent to the Supplier, terminate the Contract in whole or in part:
- a) if the Supplier fails to deliver any or all of the goods within the time period(s) specified in the Contract, or any extension thereof granted by the Purchaser; or
  - b) if the Supplier fails to perform any other obligation(s) under the Contract; or
  - c) if the Purchaser is of opinion that the goods does not conform to the specification and/or drawings
- 20.2 In the event the Purchaser terminates the Contract in whole or in part, the Purchaser may procure, upon such terms and in such manner as it deems appropriate, goods or services similar to those undelivered or unacceptable, However, the Supplier shall continue performance of the Contract to the extent not terminated.
- 21. Force Majeure**
- 21.1 For purposes of this Contract, "Force Majeure" means an event beyond the control of the parties to the Contract and not involving either party's fault or negligence and not foreseeable.
- 21.2 If, at any time during the existence of the Contract, either party is unable to perform in whole or part any obligation under this Contract because of such events which include, but are not restricted to, acts of God, acts of Government in its sovereign capacity, war, revolutions, hostility, civil commotions, strikes, fires, floods, epidemics, quarantine restrictions, freight embargoes, explosions, then the date of fulfillment of Contract shall be postponed during the period when such circumstances are operative.
- 21.3 The party which is unable to perform its obligations under the present Contract shall, within fourteen (14) days of occurrence of the Force Majeure event, inform the other party with suitable documentary evidence. Non-availability of materials from regular sources or disruption of power supply shall not be an excuse for the Supplier for not performing its obligations under this clause.
- 21.4 Any waiver/extension of time in respect of the delivery/ acceptance of any installment or part of the goods shall not be deemed to be a waiver/extension of time in respect of the remaining deliveries.
- 21.5 If such inability to perform continues for a period of more than three (3) months, each party shall have the right to be released

- from further performance of the Contract, in which case, neither party shall have the right to claim damages from the other. All prior performance shall be subject to Contract terms.
- 21.6 If a Force Majeure situation arises, the Supplier shall promptly notify the Purchaser in writing of such condition and the cause thereof. Unless otherwise directed by the Purchaser in writing, the Supplier shall continue to perform its obligations under the Contract as far as is reasonably practical and shall seek all reasonable alternative means for performance not prevented by the Force Majeure event.
- 22. Termination for Insolvency** The Purchaser may at any time terminate the Contract by giving written notice to the Supplier, without compensation to the Supplier, if the Supplier becomes bankrupt or otherwise insolvent, provided that such termination will not prejudice or affect any right of action or remedy which has accrued or will accrue thereafter to the Purchaser.
- 23. Termination for Convenience**
- 23.1 The Purchaser, by written notice sent to the Supplier, may terminate the Contract, in whole or in part, at any time convenient to it. The notice of termination shall specify that termination is for the Purchaser's convenience, the extent to which performance of the Supplier under the Contract is terminated, and the date upon which such termination becomes effective.
- 23.2 The Goods that are complete and ready for delivery within 15 days after the Supplier's receipt of notice of termination shall be accepted by the Purchaser at the Contract terms and prices. For the remaining Goods, the Purchaser may elect:
- a) to have any portion completed and delivered at the Contract terms and prices; and/or
  - b) to cancel the remainder and pay to the Supplier an agreed amount for partially completed Goods and Services and for materials and parts previously procured by the Suppliers.
- 24. Resolution of Disputes**
- 24.1 The Purchaser and the Supplier shall make every effort to resolve amicably by direct informal negotiation any disagreement or dispute arising between them under or in connection with the Contract.
- 24.2 If, after twenty-eight (28) days from the commencement of such informal negotiations, the Purchaser and the Supplier have been unable to resolve amicably a Contract dispute, either party may require that the dispute be referred for resolution to the formal mechanisms. These mechanisms may include, but are not restricted to, conciliation mediated by a third party, adjudication in an agreed national or international forum, and/or national and international arbitration.
- 25. Governing Language** The Contract shall be written in the English language. The English version of the Contract shall govern its interpretation. All correspondence and other documents pertaining to the Contract which are exchanged by the parties may be written in Nepali and/or English language.
- 26. Applicable Law** The Contract shall be interpreted in accordance with the laws of Nepal.
- 27. Notices**
- 27.1 Any notice given by one party to the other pursuant to the Contract shall be sent to the other party in writing and confirmed in writing to the other party's address. Notice sent by facsimile or by email does not need confirmation of the receiver.



27.2 A notice shall be effective when delivered or on the notice's effective date, whichever is later.

**28. Taxes and Duties**

The Supplier shall be entirely responsible for all taxes, duties, license fees, etc., incurred until delivery of the contracted Goods to the final destination point.

**29. Corruption**

The Suppliers shall adhere to the highest ethical standards, both during the bidding process and throughout the execution of a contract. A "corrupt practice" refers to the offering, giving, receiving or soliciting (directly or indirectly) of anything of value to improperly influence the actions of another person. Corruption in the procurement process generally involves a fraudulent act such as bribery or a kickback. Contractually supplier shall declare that they are not engaged in corrupt practices; they must disclose any situation that may appear to be a conflict of interest. Helvetas Nepal has a "zero tolerance" policy regarding acceptance of gifts or hospitality; and there are restrictions on employment of former Helvetas Nepal staff members.

**30. Blacklist**

The purchaser cannot continue the contract with the firm/company as and when blacklisted by the Government of Nepal to the limitation of blacklisting decision.



## 9. SPECIAL CONDITIONS OF CONTRACT (SCC)

This SCC is a integral part of the Agreement

Clause	Item
GCC 1.1 (e)	The Purchaser is: <b><u>Integrated Water Resources Management Programme Helvetas Nepal, Surkhet.</u></b>
ITB 22	The Currency of the performance security shall be in Nepalese Rupees. The amount of the performance security shall be as follows: The successful bidder should submit a performance guarantee, issued by "A" class commercial bank specified by Nepal Rastra Bank in favour of <b>Water Resources Management Programme (WARM-P), Helvetas Nepal</b> with a validity of <b>90 days</b> from date of award notification. The amount of performance security should be minimum of 10% of contractual amount.
GCC 11	The warranty period shall be ..... months/year [N/A]
GCC 12	The terms of payment to be made to the Supplier under the contract shall be as follows: <b>1. The payment shall be made:</b> <b>(a)</b> through a/c payee cheque from account division/unit of the Purchaser after successful completion of the contract.
GCC 14.4	Additional order: the purchaser can place order for additional quantity within price validity period under this agreement if required. The delivery date for additional quantity will be fixed on mutual understanding between both parties for additional order.
GCC.....	The successful bidder must submit copy of tax clearance certificate f/y 2078/2079 along with performance guarantee at the time of signing the contract. If the bidder fails to submit such document within specified period, the purchaser holds right to award the contract to next lowest evaluated substantially responsive bid or decide as per purchaser's convenience.
GCC .....	<b>For notices, the Purchaser's address shall be:</b> The Team Leader Integrated Water Resources Management Programme, Helvetas Nepal  Email: water.np@helvetas.org G.P.O. Box - 688, Kathmandu, Nepal, Tel: 977-01-5524926/5522013 <b>OR</b> Surkhet office Ittram-7, Birendranagar, Surkhet Ph: 083-521092/093  <b>For notices, the Supplier's address shall be:</b> Name and Address of the Supplier: Telephone number: Facsimile number: e-mail Address:

---

## 10. SAMPLE FORMS AND FORMATS

---

### 10.1 CONTRACT AGREEMENT

THIS AGREEMENT made on the ..... day of ..... between Integrated Water Resources Management Programme, Helvetas Nepal, Birendranagar, Surkhet (hereinafter "the Purchaser"), of the one part, and M/s ..... of ..... , Nepal (hereinafter "the Supplier"), of the other part:

WHEREAS the Purchaser invited Bids for certain Goods and Related Services, viz **supply and delivery of various construction materials for drinking water and sanitation schemes** and has accepted a Bid by the Supplier for the supply of those Goods and Related Services in the sum of NRs. .... [in words .....] (hereinafter "the Contract Price").

NOW THIS AGREEMENT WITNESSETH AS FOLLOWS:

1. In this Agreement, words and expressions shall have the same meanings as are respectively assigned to them in the Contract referred to.
2. The following documents shall be deemed to form and be read and construed as part of this Agreement, viz.:
  - (a) the Letter of Acceptance;
  - (b) the Bid Submission Sheet and the Price Schedules submitted by the Supplier;
  - (c) the Special Conditions of Contract;
  - (d) the General Conditions of Contract;
  - (e) the Schedule of Supply; and
  - (f) any other documents shall be added here.

This Contract shall prevail over all other Contract documents. In the event of any discrepancy or inconsistency within the Contract documents, then the documents shall prevail in the order listed above.

3. In consideration of the payments to be made by the Purchaser to the Supplier as indicated in this Agreement, the Supplier hereby covenants with the Purchaser to provide the Goods and Related Services and to remedy defects therein in conformity in all respects with the provisions of the Contract.
4. The Purchaser hereby covenants to pay the Supplier in consideration of the provision of the Goods and Related Services and the remedying of defects therein, the Contract Price or such other sum as may become payable under the provisions of the Contract at the times and in the manner prescribed by the Contract.
5. The suppliers should be issue VAT invoice in the name of **Integrated Water Resources Management Programme, Helvetas Nepal, Surkhet** and roughly corrected invoices will not be accepted.
6. The purchaser can place order for additional quantity within price validity period under this agreement if required. The delivery date for additional quantity will be fixed on mutual understanding between both parties for additional order.

IN WITNESS whereof the parties hereto have caused this Agreement to be executed in accordance with the laws of Nepal on the day, month, and year indicated above.

**On behalf of**

Integrated Water Resources Management Programme,  
Helvetas Nepal

Signature:

Name:

Designation:

Date:

Seal:

**Witness,**

Signature:

Name:

**On behalf of the Supplier**

Signature:

Name:

Designation:

Date:

Seal:

Signature:

Name:





**10.2 PERFORMANCE SECURITY**

[insert Bank's Name, and Address of Issuing Branch or Office]

Date: [insert date]

Beneficiary: **Water Resources Management Programme  
(WARM-P)/Helvetas Nepal  
Surkhet**

Date: .....

Performance Guarantee No.:

We have been informed that . . . name of the supplier. . . . .  
(hereinafter called "the Supplier") has entered into Contract No. . . . . reference  
number of the contract. . . . . dated . . . . . with you, for the  
execution of . . . . . name of contract and brief description of  
goods and related services. . . . . (hereinafter called "the Contract").

Furthermore, we understand that, according to the conditions of the Contract, a performance  
guarantee is required.

At the request of the Supplier, we . . . . . name of the  
bank. . . . . hereby irrevocably undertake to pay you any  
sum or sums not exceeding in total an amount of . . . . . name of the  
currency and amount in words . . . . . (.  
. . . . . amount in figures. . . . .) such sum  
being payable in the types and proportions of currencies in which the Contract Price is  
payable, upon receipt by us of your first demand in writing accompanied by a written statement  
stating that the Supplier is in breach of its obligation(s) under the Contract, without your  
needing to prove or to show grounds for your demand or the sum specified therein.

This guarantee shall expire, no later than the . . . . . day of . . . . .  
. . . , and any demand for payment under it must be received by us at this office on or before  
that date.

.....  
Signature(s) and seal of bank (where appropriate)





**10.3 BID SECURITY**

[insert Bank's Name, and Address of Issuing Branch or Office]

Date: [insert date]

**Beneficiary Name:** Water Resources Management Programme (WARM-P),  
Helvetas Nepal, Surkhet

**BID GUARANTEE No.:** [insert guarantee number]

We have been informed that [insert name of the bidder] (hereinafter called "the bidder") intends to submit its bid to you (hereinafter called "the Bid") for the execution of [insert name of procurement contract] under Invitation for Bids No. [insert contract number] ("the Invitation").

Furthermore, we understand that, according to your conditions of contract, bids must be supported by a bid guarantee.

We [insert name of issuing Bank] hereby irrevocably undertake to pay you a total amount of [insert amount in figures of bid security] [insert amount in words] upon receipt by us of your first demand in writing accompanied by a written statement stating that the bidder is in breach of its obligation under the bid conditions.

This guarantee will expire in ..... days after the expiration of the bidder's bid which comes to be [insert the date of expiry of the bid security].

Consequently, any demand for payment under this guarantee shall be received by us at the office on or before expiry date of bid security.

Name \_\_\_\_\_  
In the capacity of \_\_\_\_\_  
Signed \_\_\_\_\_

Duly authorized to sign the Bid Security for and on behalf of \_\_\_\_\_  
Date \_\_\_\_\_



**10.4 LETTER OF ACCEPTANCE**

[on letterhead paper of the Purchaser]

Date.....

To: Name and address of the Supplier

Subject: Notification of Award

This is to notify that your sealed bid related to bid notice dated ..... for supply and delivery of Package ..... for the Contract price of Nepalese Rupees ..... (in words: ..... only) has been accepted by us in accordance with the Instruction to bidders.

You are hereby informed to contact this office for formal contract agreement latest by ..... before 5:00 PM accompanying an unconditional performance security of NRs. .... (in words: ..... only) from a "A" class commercial bank specified by Nepal Rastra Bank in favour of **Water Resources Management Programme (WARM-P), Helvetas Nepal, Surkhet**. The validity of performance security must be **90 days**. As per the Conditions of Contract, you are also required to submit performance guarantee, as specified in the format included in the Bidding Document.

In case you fail to furnish the performance security and to sign the contract within specified period, the purchaser reserves the right to cancel this award notification.

Authorized Signature: .....

Name and Title of Signatory:

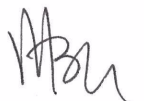

---

## 11. ANNEX-I

---

### Code of Conduct for Contracted Parties

#### 1. Scope of this Code of Conduct

HELVETAS Swiss Intercooperation (hereinafter HELVETAS) is a civil society organisation for development and humanitarian response. We strive to empower people, so they can determine the course of their lives in dignity and security, using environmental resources in a sustainable manner. Our work is guided by the following values<sup>1</sup>:

- Our engagement is based on solidarity and partnership.
- We work towards achieving human rights and upholding the principle of self-determined development.
- We are committed to social equity and strive for equal opportunities for men and women regardless of age, origin, language, religion, culture, mental and physical capacity, sexual orientation, or political convictions.
- Our collaboration with our partners is based on mutual respect for cultural values and principles
- We stand for development that balances economic viability, environmental appropriateness and social benefits.

The organisational values are the basis for the attitude, behaviour and high standards that HELVETAS requests to be respected and adhered to by its employees.

Further, we expect that all individuals and institutions with whom HELVETAS engages, respect these values and act in accordance with them, as well as with national and international laws. This applies both to professional contexts and to private matters that have an influence on the professional domain.

This Code of Conduct outlines the attitude and the behaviour that HELVETAS expects from consultants, services providers of goods and services, implementation partners, system partners and assisted organisations – in the following called **contracted parties** – that are responsible for implementing projects, project components and/or recipients of contributions, etc. in Switzerland as well as abroad.

This Code of Conduct is binding, and an integral part of all contractual agreements made between HELVETAS and its contracted parties. In signing their contract, contracted parties take on the commitment to observe the Code of Conduct, to ensure adherence by their personnel and their subcontractors, and to behave accordingly. Any action violating the Code of Conduct may entail an enquiry and the imposition of measures relating to non-compliance with contractual obligations, or of other measures.

Contracted parties are expected to ensure that their employees and any person working for them adhere to this Code of Conduct by putting in place adequate policies and regulations and through sensitisation, supervision and training of concerned persons.

---

<sup>1</sup> Organisational Strategy HELVETAS Swiss intercooperation



## 2. The Components of the Code of Conduct

<b>Loyalty and confidentiality and civic duty</b>	The actions of contracted parties in the frame of the collaboration with HELVETAS must be consistent with the goals, the values and principles of HELVETAS as expressed in its mission statement and organisational strategy. Contracted parties are expected to regularly reflect upon own actions and behaviour and those of subcontractors. Contracted parties, their employees and subcontractors commit to abide by the national laws, as citizen or resident of a specific country or as a short-term visitor.
<b>Use of competences, means and assets</b>	Contracted parties, their employees and subcontractors contribute with their competences and capacities to the objectives of the collaboration. They commit to make use of available means and assets effectively and efficiently, according to legal stipulations, internal regulations, contractual agreements and in conformity with project goals.
<b>Culturally sensitive behaviour</b>	Contracted parties, their employees and subcontractors are aware that even as private persons, they are subject to public interest. They must consider this in behaviour and statements. Contracted parties, their employees and subcontractors must respect local norms and conventions in contacts with authorities, partners and local people. They must respect the customs and culture of the country of cooperation in appearance and manner of dress, behaviour and communication. They must respect the customs and culture of the country, avoiding indecent or offensive behaviour, insulting or accusing statements, or spreading rumours.
<b>Inter-personal relations and professional conduct</b>	Contracted parties, their employees and subcontractors must have respectful, fair and equitable relations with all persons irrespective of their age, origin, language, religion, culture, social position, physical ability or sexual orientation. They are aware of their privileged and often powerful status vis-à-vis other actors and must refrain from abusing any hierarchical, material, or social position in any way. They never request any service or favour from primary stakeholders or other persons of concern in return for support or protection. They never engage in any exploitative relationships – sexual, emotional, financial or employment-related – with primary stakeholders or other persons of concern. They must refrain from any form of disrespectful social interaction and abstain from anything that could be interpreted as degrading or putting others down.
<b>Protection of children and youth</b>	Contracted parties, their employees and subcontractors commit to protect the rights and integrity of children and youth and must refrain from all forms of abuse towards them in accordance with the universal Convention on the Rights of the Child. <sup>2</sup>
<b>Mobbing and sexual harassment</b>	Contracted parties, their employees and subcontractors abstain from mobbing <sup>3</sup> , sexual or sexist harassment <sup>4</sup> of colleagues, partners or any other person.

<sup>2</sup> <https://www.ohchr.org/en/professionalinterest/pages/crc.aspx>

<sup>3</sup> **Mobbing** means to pick on, pester or exclude a person or a group systematically at work in verbal or non-verbal attacks which affect the physical or mental health as well as the self-esteem of the person(s) concerned

<sup>4</sup> **Sexual or sexist harassment** is an action with sexual reference or undertones unwelcome to the person addressed. Sexual or sexist harassment can be expressed in the following ways: suggestive remarks; remarks about physical advantages or weaknesses or about sexual orientation; sexist talk and jokes in any form of verbal, written or non-verbal communication;



<b>Conflict of Interest and duty of disclosure</b>	Contracted parties, their employees and subcontractors are aware that professional interests can conflict with organisational or personal interests. Therefore, they must make own interests transparent and avoid any behaviour which could be perceived as biased in favour own interests.
<b>Fraud and corruption and accepting gifts or other benefits</b>	Contracted parties, their employees and subcontractors are must be honest in all professional activities, avoiding and countering any kind of corruption. They abstain from abusing financial, material and intellectual assets to which they have access in relation with the HELVETAS mandate for personal gains or for third parties. They do not accept gifts, invitations or other favours that may afford them or third parties an unfair material or immaterial advantage, or that may compromise their integrity, freedom of action, or impartial judgement. Contracted parties must inform HELVETAS if confronted with corrupt practices or unethical promises by collaborators, partners organization, consultants, officials or others. The applicable reporting mechanisms are specified in chapter 3 of this Code of Conduct.
<b>Safety, Security &amp; Health</b>	Contracted parties undertake to safeguard the personal safety, health and integrity of their employees and refrain from putting others in a dangerous situation. Contracted parties, their employees and subcontractors must respect the physical and mental integrity of their colleagues and others.
<b>Environmental and Social Safeguarding</b>	Contracted parties, their employees and subcontractors are expected to wherever possible support a precautionary approach to environmental matters and undertake efforts to safeguard natural resources. Contracted parties must promote good governance principles, namely participation, inclusion, integrity, effectiveness, transparency, rule of law, and accountability. Contracted parties, their employees and subcontractors must ensure that their professional actions and their motivations are understood and transparent.
<b>Public appearances and use of non-public information</b>	Contracted parties handle all information received in relation with the contract with the necessary discretion, never using it to the detriment of HELVETAS or beneficiaries including after termination of the contract. Persons working for contracted parties should not provide aforesaid information to the media, policy makers and donors or the public, without an explicit assignment to do so. In public communication they must provide explicit reference to the sources of the information/experiences. They must refrain from making accusations, provocative statements or spreading rumours. They give due consideration to their cooperation with HELVETAS and to its interests in their communications, particularly via the internet or social media

### 3. Reporting mechanism of a violation of the Code of Conduct and Whistleblowing

Any person working for a contracted party of HELVETAS who feels under pressure to act in a way that runs counter to this Code of Conduct, or who witnesses violations of the same, must inform either the management of the contracted party and/or HELVETAS. The contracted party is obliged to share the reported cases and action taken with HELVETAS.

sharing suggestive material over email or social media; ambiguous invitations; making bodily advances; making advances together with promises or threats of advantages or disadvantages at work.

The whistleblowing policy (e.g. whistle-blower protection) of HELVETAS applies to all employees worldwide and to persons working for contracted parties. All concerns will be treated confidentially, and every effort will be made not to reveal the identity of the whistleblower. The policy is publicly available on HELVETAS' website and the specified contacts are accessible for anyone.

**4. Consequences of a violation of this Code of Conduct**

In case of breach of this Code of Conduct by contracted parties, their employees and subcontractors, HELVETAS expects them to sanction misbehaving persons similar to HELVETAS' measures. These sanctions range from requesting apologies, written warnings to dismissal of guilty persons. In serious cases or if no appropriate sanctions are taken, HELVETAS reserves the right to end the collaboration, ask for compensation of financial losses or to pursue legal action.

**5. Final Remarks**

HELVETAS encourages its contracted parties to create their institutional codes of conducts and related policies and regulations, including internal reporting procedures that enable their employees and subcontractors, as well as third parties, to promote professional, respectful, inclusive and secure working conditions; and safely report instances of wrongdoing to the management or to an independent body.

HELVETAS is committed to mutual transparency and learning on any aspect of this Code of Conduct. HELVETAS is therefore available for consultation in cases of doubt or questions relating to the Code of Conduct.

This Code of Conduct is issued in French, English and Spanish. In case of any doubts, the English version prevails.

Read and agreed

Name of the contracted party: .....

Name of signatory of contracted party:.....

Place and date .....

Signature:

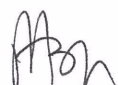
A handwritten signature in blue ink, appearing to be "A. Bon", is written over the bottom right portion of the HELVETAS logo.